

CE



CHRISTIE
TOTAL TORQUE SOLUTIONS

DIGITAL BATTERY TORQUE WRENCH (DB-RAD) USER GUIDE



CONTENTS

<u>Page</u>	<u>Description</u>
1	Introduction
2	Training Requirements General Safety
3	Battery Pack Safety DB-RAD Wrench Models Covered By Manual Noise & Vibration Levels
4	Accessories Available to Buy or Hire DB-RAD Wrench Features LCD Display Screen Navigation
5-12	LCD Display Screen Interface
5	Main Screen
5	User Access Levels
6	Unlocking Access Levels
6-7	Returning to the Locked Level
7	Functions
7	Select a Pre-set
8	Hard Joint Mode
8	View Tool Information
9	View Last Result
9	View Life Cycles
10	View Maintenance Cycles
10	Change Target Torque
10-11	Save a Pre-set
11	Change the Torque Units
11-12	Set the Clock
12	Clear Maintenance Cycles
13	Torque Reaction
14	Safe Reaction Zone
15	Setting Torque For Bolt Tightening Setting Torque For Bolt Loosening
16	Operating The Wrench Maintenance And Recalibration
17	Battery Charging / Changing
18	E.C. Declaration of Conformity
--	Calibration Certificate

INTRODUCTION

The DB-RAD Digital Battery Torque Wrench is a handheld, battery driven reversible non-impacting torque delivery power tool intended to tighten and un-tighten nuts, bolts and threaded fasteners.

The DB-RAD Electrical torque wrench must always be used with the following:-

- Battery Pack Supplied
- Impact Quality Sockets
- Ring and pin fastener system (or similar)
- Reaction Arm
- 240V or 110V electrical battery charger (dependant on model purchased)

If the intended use is other than for nuts, bolts and threaded fasteners contact W. Christie (Industrial) LTD for guidance.

It is the responsibility of the user to consider associated site risks before introducing the equipment into the work-place.

TRAINING REQUIREMENTS

Training on the correct use of the DB-RAD Digital Battery Torque Wrench is available. Please contact W. Christie (Industrial) LTD for more information.

GENERAL SAFETY

The improper use of the DB-RAD Digital Battery Torque Wrench is unsafe and may result in personal injury. It is important that operators have read, understood and comply with all instructions in this user guide.

Operators must be equipped with the following personal protective equipment (PPE):

- Eye Protection (Safety Glasses / Goggles)
- Safety Footwear (Steel Toe Cap Boots)
- Heavy Gloves

Impact quality sockets must be secured to the tool square drive by means of a ring and pin combination.

Only use DB-RAD Wrenches with impact quality sockets. Do not use with extension bars or universal joints.

Do not use in the presence of explosive gases or liquids - fire/explosion hazard

Only use DB-RAD wrench battery charger with 240v or 110v electrical power supply (dependant on model purchased)

To prevent entanglement with rotating parts operators must not wear loose clothing, ties, jewellery etc... Long hair must be tied back.

Always keep hands, fingers and body parts clear of the reaction arm at all times. Trapping in this area can result in serious personal injury.

All equipment and ancillary products should be inspected for damage and irregularities prior to use. If in doubt **do not use**.

IMPORTANT:- DB-RAD WRENCHES RELY ON AN INTERNAL CLUTCH TO REGULATE TORQUE OUTPUT. AS THE CLUTCH WEARS, TORQUE OUTPUT MAY VARY. IT IS STRONGLY ADVISED THAT WHEN USING DB-RAD WRENCHES FOR ANY BOLTING WORK, TOOLING IS CHECKED FOR TORQUE ACCURACY ON SUITABLE TEST EQUIPMENT PRIOR TO USE. FOR APPLICATIONS OF A CRITICAL NATURE, DB-RAD WRENCHES MUST BE TORQUE CHECKED DAILY.

W. CHRISTIE (INDUSTRIAL) LTD OFFER A TORQUE CHECKING SYSTEM (RUN DOWN FIXTURE) FOR SALE OR HIRE TO MONITOR THE TORQUE OUTPUT OF ALL TORQUE TOOLS BETWEEN ANNUAL CALIBRATION DATES.

BATTERY PACK SAFETY

Only use the DB-RAD Li-Ion Battery Pack with the DB-RAD Tool System. The use of other batteries with the DB-RAD Tool System will cause damage to the tool.

The DB-RAD Li-Ion Battery Pack should only be charged on the DB-RAD Battery Charger. If an incompatible charger is used, damage to the DB-RAD Battery will occur.

Keep the DB-RAD Li-Ion Battery Pack away from any metal objects. If the battery terminals are connected by a metal object, the battery will short and will cause damage to the battery and injury to the operator.

Do not expose the DB-RAD Li-Ion Battery Pack to wet conditions. This will cause damage to the DB-RAD Battery and increase the risk of electric shock.

Do not use faulty or deformed DB-RAD Batteries. Do not attempt to open the DB-RAD Battery. Do not short circuit the DB-RAD Battery. Failure to comply will cause damage to the DB-RAD Battery and injury to the operator.

If liquid is ejected from the DB-RAD Battery, avoid contact. If contact occurs, immediately flush with water. If contact with eyes occurs, immediately flush with water and seek medical aid. Liquid from the DB-RAD Battery may cause irritation and/or burns.

DB-RAD Li-Ion Battery Packs cannot be disposed of with regular waste. Return DB-RAD Batteries to W. Christie Industrial (LTD)

DB-RAD WRENCH MODELS COVERED BY MANUAL

Model	Weight (Kg)	Max Speed (RPM)		Torque Range (Nm)		Square Drive
		Single	Auto 2	Minimum	Maximum	
DB-RAD 475	4.4	22.5	N/A	80	475	3/4"
DB-RAD 700	4.0	12	N/A	150	700	3/4"
DB-RAD 1400	4.3	5.5	N/A	220	1,400	3/4"
DB-RAD 2000	4.3	3	N/A	510	2,000	1"

NOISE & VIBRATION LEVELS

NOISE: Equivalent continuous A weighted sound pressure level is less than 85 dB(A).

VIBRATION: Vibration level at handle does not exceed 2.5m/sec.

ACCESSORIES AVAILABLE TO BUY OR HIRE

The following accessories are available upon request and can be custom made to suit requirements. Please contact W. Christie (Industrial) LTD for more information:-

- Special Reactions.
- Nose Cone Extension.
- Offset Gearbox.
- Impact Quality Sockets.
- Torque Checking System (Run Down Fixture)

DB-RAD WRENCH FEATURES

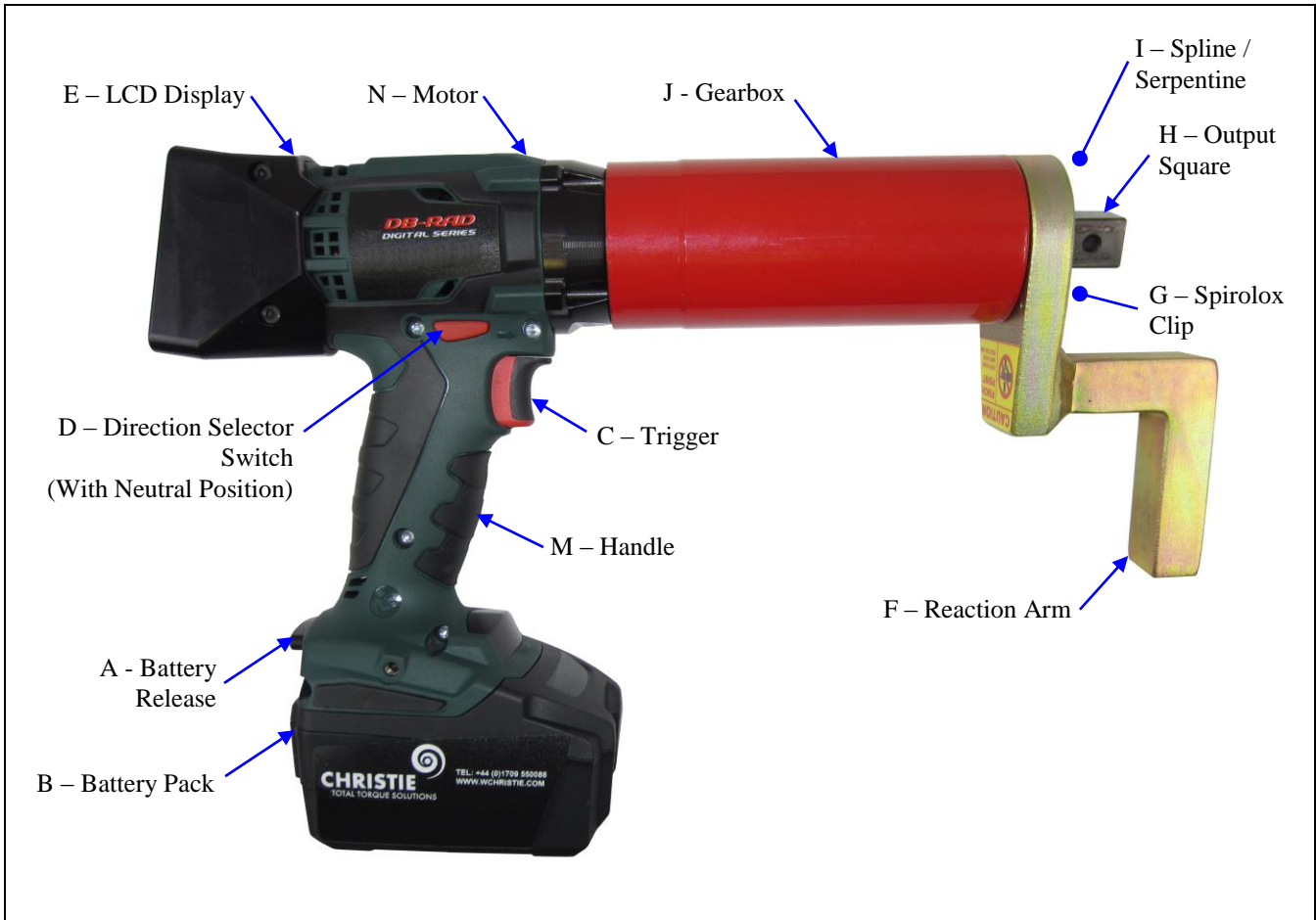

LCD DISPLAY SCREEN NAVIGATION

The keypad located below the LCD Display (E) consists of three buttons used to navigate the DB-RAD Interface. The “Up Arrow” button is used to increment through values and navigate through columns. The “Down Arrow” button is used to decrement through values and navigate through rows. The “Centre” button is used to select options and enter the Main Menu.

NOTE When pressing the navigation buttons, press and hold for about a second. This will ensure that the button pressed was properly registered

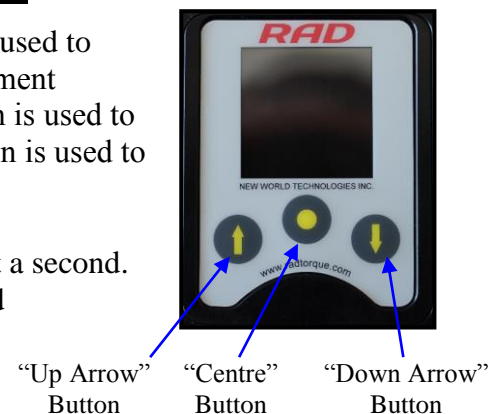

LCD DISPLAY SCREEN INTERFACE

CAUTION LCD Displays are susceptible to mechanical shock and any force exerted on the module may result in damage.

CAUTION LCD Displays can be damaged by moisture or water and high temperatures. Avoid such conditions when storing and gently wipe clean or let dry before usage.

The DB-RAD Controller includes an LCD Display. This simple LCD Display interface has many functions including pre-sets, Torque Settings and Calibration. The following sections describe these functions, as well as how to enable and/or use them.

Refer to “LCD Display Screen Navigation” Section to understand the use of the buttons referred to in this section.

Main Screen

The Main Screen is used as the central control point of the DB-RAD Tool System. The Target Torque, Torque Units, DB-RAD Model and Tool Status are displayed on the Main Screen. Figure Right shows the main screen and indicates important aspects.



User Access Levels

Access to the functions on the LCD Display has been constricted to four Access Levels: the Locked Level, the Basic Level, the Intermediate Level and the Advanced Level. Access to the last three levels requires a password. Each level has a different password and access to different functions. The table below outlines the functions accessible to each level.

User Access Levels and Functions				
Functions	Level			
	Locked	Basic	Intermediate	Advanced
Selecting a Preset	YES	YES	YES	YES
Hard Joint Mode	YES	YES	YES	YES
View Tool Information	YES	YES	YES	YES
View Last Result	YES	YES	YES	YES
View Life Cycles	YES	YES	YES	YES
View Maintenance Cycles	YES	YES	YES	YES
Change Target Torque	NO	YES	YES	YES
Save a Preset	NO	YES	YES	YES
Change Torque Units	NO	YES	YES	YES
Set the Clock	NO	NO	NO	YES
Clear Maintenance Cycles	NO	NO	NO	YES
Tool Calibration	NO	NO	NO	YES
Default Calibration	NO	NO	NO	YES

Note: The DB-RAD Tool System is shipped from factory in the Basic Level. After configuration, it is recommended that the tool be locked for normal bolting operations to avoid inadvertent changes to tool settings and calibration.

Unlocking Access Levels

To unlock an Access Level:

- 1) Press the “Centre” button.
Result: The Main Menu screen will be displayed (Main Menu Screen)
- 2) Press the “Down Arrow” button to highlight the “Unlock” option.
- 3) Press the “Centre” button.
Result: The Password Input screen will be displayed (See Password Input Screen)
- 4) Use the navigation keypad to enter the desired password.

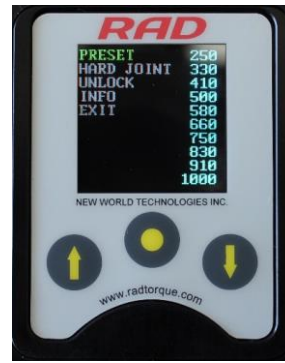

Main Menu Screen

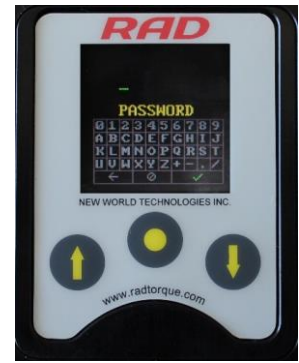

Password Input Screen

- Note:** Use the “Up Arrow” button to move horizontally (↔) across the Password Keyboard. Use the “Down Arrow” button to move vertically (↕) on the Password Keyboard. Use the “Centre” button to select the highlighted character.
- 5) Select the “Check Mark” key (✓) on the Password Keyboard to enter the password.

- Note:** Select the “Back Arrow” key (←) to delete the previous character. Select the “Cancel” key (∅) to return to the Main Menu screen without entering a password.

Result: The Main screen will be displayed and the DB-RAD is now unlocked to the desired Access Level (See Main Screen in the Basic, Intermediate or Advanced Level)



Main Screen in the Basic, Intermediate or Advanced Level

- Note:** The Lock Icon is not visible.

ACCESS LEVELS AND PASSWORDS	
Access Level	Passcode
Basic	37232
Intermediate	Contact W. Christie (Industrial) LTD
Advanced	W. Christie (Industrial) LTD Only

Returning to the Locked Level

To return to the Locked Access Level:

- 1) Press the “Centre” button.
Result: The Main Menu screen will be displayed (See Main Menu Screen).
- 2) Press the “Down Arrow” button to highlight the “Lock” option.
- 3) Press the “Centre” button.
Result: The Password Input screen will be displayed (See Password Input Screen).
- 4) Use the navigation keypad to enter the Basic Level Password.

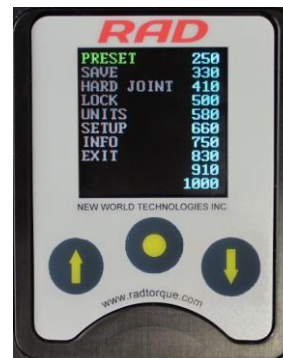

Main Menu Screen

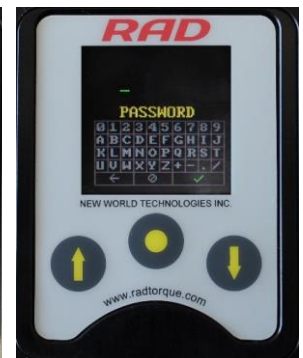

Password Input Screen

Note: Use the “Up Arrow” button to move horizontally (↔) across the Password Keyboard. Use the “Down Arrow” button to move vertically (↓) on the Password Keyboard. Use the “Centre” button to select the highlighted character.

- 5) Select the “Check Mark” key (✓) on the Password Keyboard to enter the password.

Note: Select the “Back Arrow” key (←) to delete the previous character. Select the “Cancel” key (∅) to return to the Main Menu screen without entering a password.

Result: The Main screen will be displayed and the DB-RAD will be in the Locked Access Level (See Main Screen in Locked Level).

Note: The Lock Icon is visible

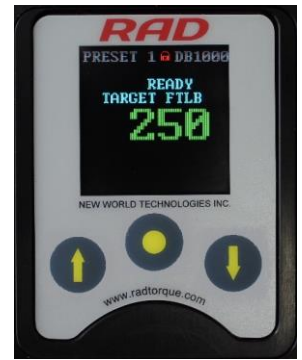

Main Screen in Locked Level

Functions

The following sections describe the functions available on the DB-RAD Display Interface. Refer to “User Access Levels” Section for more information on the accessibility of these functions.

Note: Menus will look different depending on the access level. The figures in this section are from the Advanced Access Level.

Select a Pre-set

A Pre-set is a pre-defined Target Torque value. They allow the operator to quickly and efficiently change the Target Torque. To select a Pre-set:

- 1) Press the “Centre” button.

Result: The Main Menu screen will be displayed (See Main Menu Screen).

- 2) Press the “Centre” button.

Result: The highlight will move to the list of Pre-sets on the right side of the screen (Pre-sets Menu Screen).

- 3) Use the “Up Arrow” button and the “Down Arrow” button to highlight the desired Pre-set.

- 4) Press the “Centre” button to select the Pre-set.

Result: The LCD Display will return to the Main screen. The Target Torque will be the Pre-set Torque and the Pre-set number will be displayed at the top of the screen (Main Screen).



Main Menu Screen



Presets Menu Screen



Main Screen

Hard Joint Mode

CAUTION Damage to the DB-RAD and the joint may occur if the Joint Rate is less than 10° and Hard Joint Mode is not enabled.

The DB-RAD is calibrated for a Joint Rate greater than 10°. The Hard Joint Mode allows the DB-RAD to operate on a joint with a Joint Rate of less than 10°.

To enable/disable Hard Joint Mode:

- 1) Press the “Centre” button.
Result: The Main Menu screen will be displayed (See Main Menu Screen).
- 2) Use the “Up Arrow” button and the “Down Arrow” button to highlight the “Hard Joint” option.
- 3) Press the “Centre” button to select the “Hard Joint” option.
Result: The LCD Display will return to the Main screen with Hard Joint displayed (See Main Screen – Hard Joint Mode).

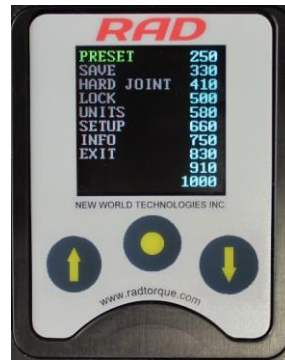

Main Menu Screen



Main Screen – Hard Joint Mode

View Tool Information

This function allows the operator to view the DB-RAD information including:

- Date and Time
- Software Version
- DB-RAD Model
- Serial Number
- Current Units
- Voltage
- Minimum Torque
- Maximum Torque

To view the Tool Information:

- 1) Press the “Centre” button.
Result: The Main Menu screen will be displayed (Main Menu Screen Image).
- 2) Use the “Up Arrow” button and the “Down Arrow” button to highlight the “Info” option.
- 3) Press the “Centre” button to select the “Info” option.
Result: The Info Menu screen will be displayed (See Info Menu Screen). The “Tool Info” option will already be highlighted.
- 4) Press the “Centre” button to select the “Tool Info” option.
Result: The Tool Information screen will be displayed (See Tool Info Screen).



Main Menu Screen

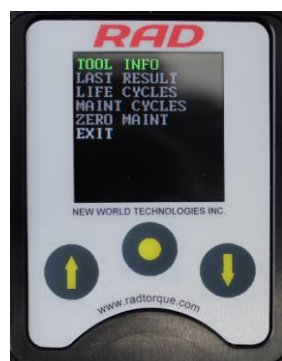

Info Menu Screen



Tool Info Screen

View Last Result

This function allows the operator to view the result of the last Torque Cycle. To view the Last Result:

- 1) Press the “Centre” button.
Result: The Main Menu screen will be displayed (See Main Menu Screen).
- 2) Use the “Up Arrow” button and the “Down Arrow” button to highlight the “Info” option.
- 3) Press the “Centre” button to select the “Info” option.
Result: The Info Menu screen will be displayed (See Info Menu Screen).
- 4) Use the “Up Arrow” button and the “Down Arrow” button to highlight the “Last Result” option.
- 5) Press the “Centre” button to select the “Last Result” option.
Result: The Last Result screen will be displayed (See Example of Last Result Screen).



Main Menu Screen

Info Menu Screen

Example of Last Result Screen

View Life Cycles

This function allows the operator to view the statistics of all the Cycles conducted over the life of the tool. To view the Life Cycles:

- 1) Press the “Centre” button.
Result: The Main Menu screen will be displayed (See Main Menu Screen Screen).
- 2) Use the “Up Arrow” button and the “Down Arrow” button to highlight the “Info” option.
- 3) Press the “Centre” button to select the “Info” option.
Result: The Info Menu screen will be displayed (See Info Menu Screen).
- 4) Use the “Up Arrow” button and the “Down Arrow” button to highlight the “Life Cycles” option.
- 5) Press the “Centre” button to select the “Life Cycles” option.
Result: The Life Cycles screen will be displayed (See Example of Life Cycles Screen)



Main Menu Screen

Info Menu Screen

Example of Life Cycles Screen

View Maintenance Cycles

This function allows the operator to view the statistics of all the Cycles conducted since the tool's last maintenance. To view Maintenance Cycles:

- 1) Press the "Centre" button.
Result: The Main Menu screen will be displayed (See Main Menu Screen).
- 2) Use the "Up Arrow" button and the "Down Arrow" button to highlight the "Info" option.
- 3) Press the "Centre" button to select the "Info" option.
Result: The Info Menu screen will be displayed (See Info Menu Screen).
- 4) Use the "Up Arrow" button and the "Down Arrow" button to highlight the "Maint Cycles" option.
- 5) Press the "Centre" button to select the "Maint Cycles" option.
Result: The Maintenance Cycles screen will be displayed (See Example of Maintenance Cycles Screen).



Main Menu Screen



Info Menu Screen

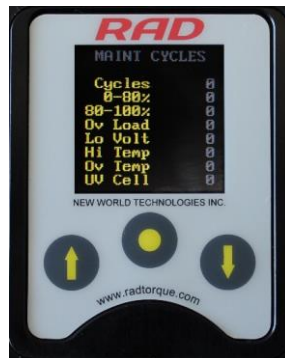

Example of Maintenance Cycles Screen

Change the Target Torque

This function allows the operator to change the Target Torque. The Target Torque is the torque value at which the DB-RAD will stop the Torque Cycle and the cycle will be considered a pass. For more information on the Target Torque and Torque Cycle, refer to "Torque Operation" Section. To change the Target Torque:

- 1) Use the "Up Arrow" button to increase the Target Torque and use the "Down Arrow" button to decrease the Target Torque.
Result: The Target Torque displayed on the Main screen will change. Once the desired Target Torque is displayed, the DB-RAD is ready for a Torque Cycle.

Save a Pre-set

This function allows the operator to modify any of the ten Pre-sets. Pre-sets are pre-defined Target Torques. For more information on using Pre-sets, refer to "Select a Pre-set" section. To save a Pre-set:

- 1) Change the Target Torque to the desired torque value (See Main Screen). Refer to "Change the Target Torque" Section.
- 2) Press the "Centre" button.
Result: The Main Menu screen will be displayed (See Main Menu Screen).



Main Screen



Main Menu Screen

- 3) Use the “Up Arrow” button and the “Down Arrow” button to highlight the “Save” options.
- 4) Press the “Centre” button to select the “Save” option.
- 5) Use the “Up Arrow” button and the “Down Arrow” button to highlight the Pre-set to be modified (See Pre-sets Menu Screen).
 - Note:** The Target Torque previously saved as this Pre-set will be overwritten by the new Target Torque.
- 6) Press the “Centre” button to select the Pre-set.
 - Result:** The Target Torque is now saved as the Pre-set and is displayed in the Pre-sets Menu (See Pre-sets Menu Screen).



Pre-sets Menu Screen



Presets Menu

Change the Torque Units

This function allows the operator to change the torque units to Pounds Feet (lbf.ft) or Newton-Meters (Nm). When the units are changed, the Target Torque value, Preset Torque Values and Calibration Values are automatically converted to the selected units. To change the torque units:

- 1) Press the “Centre” button.
 - Result:** The Main Menu screen will be displayed (See Main Menu Screen).
- 2) Use the “Up Arrow” button and the “Down Arrow” button to highlight the “Units” option.
- 3) Press the “Centre” button to select the “Units” option.
 - Result:** If the units were lbf.ft, they will change to Nm. If the units were Nm, they will change to lbf.ft.
 - Result:** The Main screen will be displayed. Confirm that the correct units are displayed (See Different units displayed on the Main Screen).



Main Menu Screen



Different Units Displayed on the Main Screen

Set the Clock

This function allows the operator to set the time and date on the DB-RAD. To set the clock:

- 1) Press the “Centre” button.
 - Result:** The Main Menu screen will be displayed (See Main Menu Screen).
- 2) Use the “Up Arrow” button and the “Down Arrow” button to highlight the “Setup” option.
- 3) Press the “Centre” button to select the “Setup” option.
 - Result:** The Setup Menu screen will be displayed (See Setup Menu Screen).



Main Menu Screen



Setup Menu Screen

- 4) Use the “Up Arrow” button and the “Down Arrow” button to highlight the “Clock” option.
- 5) Press the “Centre” button to select the “Clock” option.
Result: The Clock Setting screen will be displayed (See Clock Setting Screen).
- 6) Use the navigation buttons and the keyboard to select and edit the time and date.



Clock Setting Screen

Note: Use the “Up Arrow” button to move horizontally (↔) across the keyboard. Use the “Down Arrow” button to move vertically (↓) on the keyboard. Use the “Centre” button to select the highlighted character. Select the “Check Mark” key (✓) on the keyboard to enter. Select the “Back Arrow” key (←) to delete the previous character. Select the “Cancel” key (∅) to return to the Clock Setting screen without making a change.

- 7) Use the navigation buttons to highlight and select the “Save” option to save and exit or the “Exit” option to exit without saving.

Clear Maintenance Cycles

This function allows the operator to clear the statistics in Maintenance Cycles. To clear Maintenance Cycles:

- 1) Press the “Centre” button.
Result: The Main Menu screen will be displayed (See Main Menu Screen).
- 2) Use the “Up Arrow” button and the “Down Arrow” button to highlight the “Info” option.
- 3) Press the “Centre” button to select the “Info” option.
Result: The Info Menu screen will be displayed (See Info Menu Screen).
- 4) Use the “Up Arrow” button and the “Down Arrow” button to highlight the “Zero Maint” option.
- 5) Press the “Centre” button to select the “Zero Maint” option.



Main Menu Screen



Info Menu Screen

TORQUE REACTION

When the Christie DB-RAD wrench is in operation the reaction arm rotates in the opposite direction to the output square drive and must be allowed to rest squarely against a solid object or surface adjacent to the bolt to be tightened. (See Figure Below).

Ensure the Reaction Arm is NOT resting on a sloping or bevelled face.

SPECIAL NOTICE: TIGHT FASTENERS

When tightening or releasing tight fasteners, the torque required to move the nut may be high enough to keep the reaction locked in one position. This can cause the reaction plate to bend or cause gearbox failure. To prevent failure, re-position the reaction plate after every two turns of the fastener, i.e operate the tool briefly in the opposite direction.

TRAPPING HAZARD:-

Always keep hands, fingers and body parts clear of the reaction arm when the tool is in use or trapping injury will result

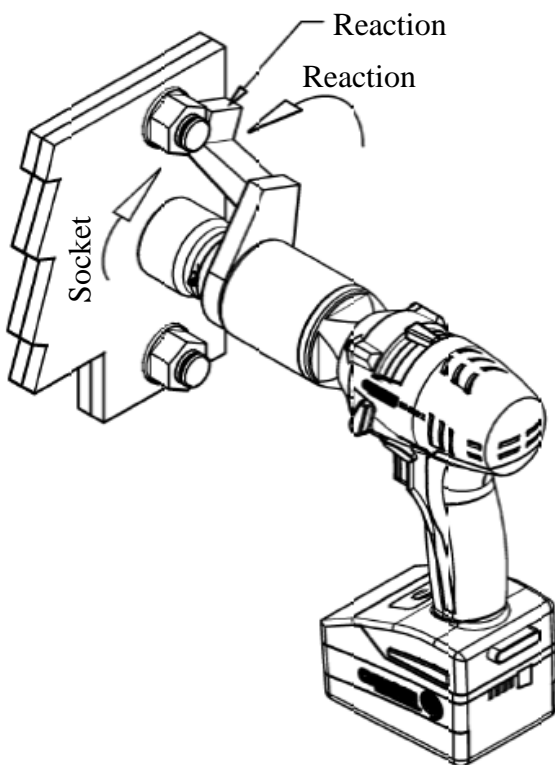

Clockwise Operation

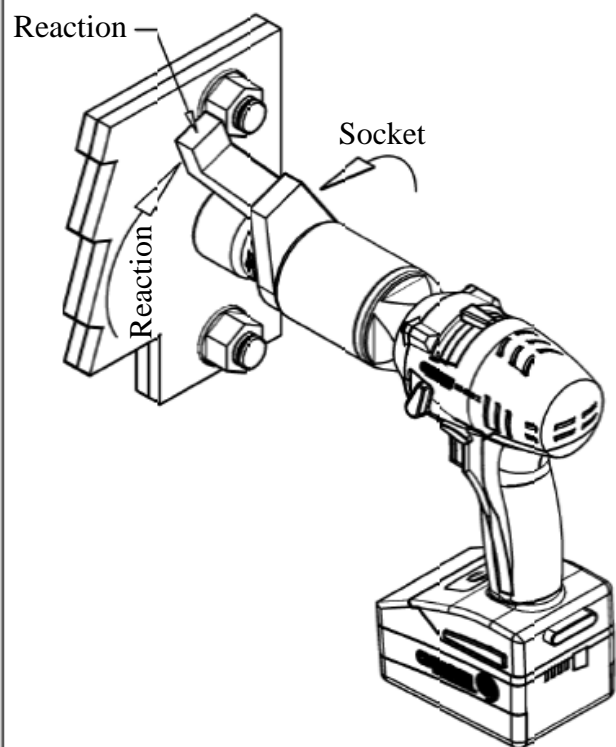

Counter Clockwise Operation

SAFE REACTION ZONE

Care must be taken to ensure that the reaction arm is only used within the limitations shown in the figure below. Failure to observe this instruction will result in premature wear or damage to the wrench. Do not react on the reaction arm vertical crank or inside edge. Extreme forces are created which may cause damage to the wrench. If the application does not allow the use of a standard reaction arm, non-standard reaction arms are available.

Customers must not modify reaction arms and are strongly advised to contact W. Christie (Industrial) LTD technical assistance.

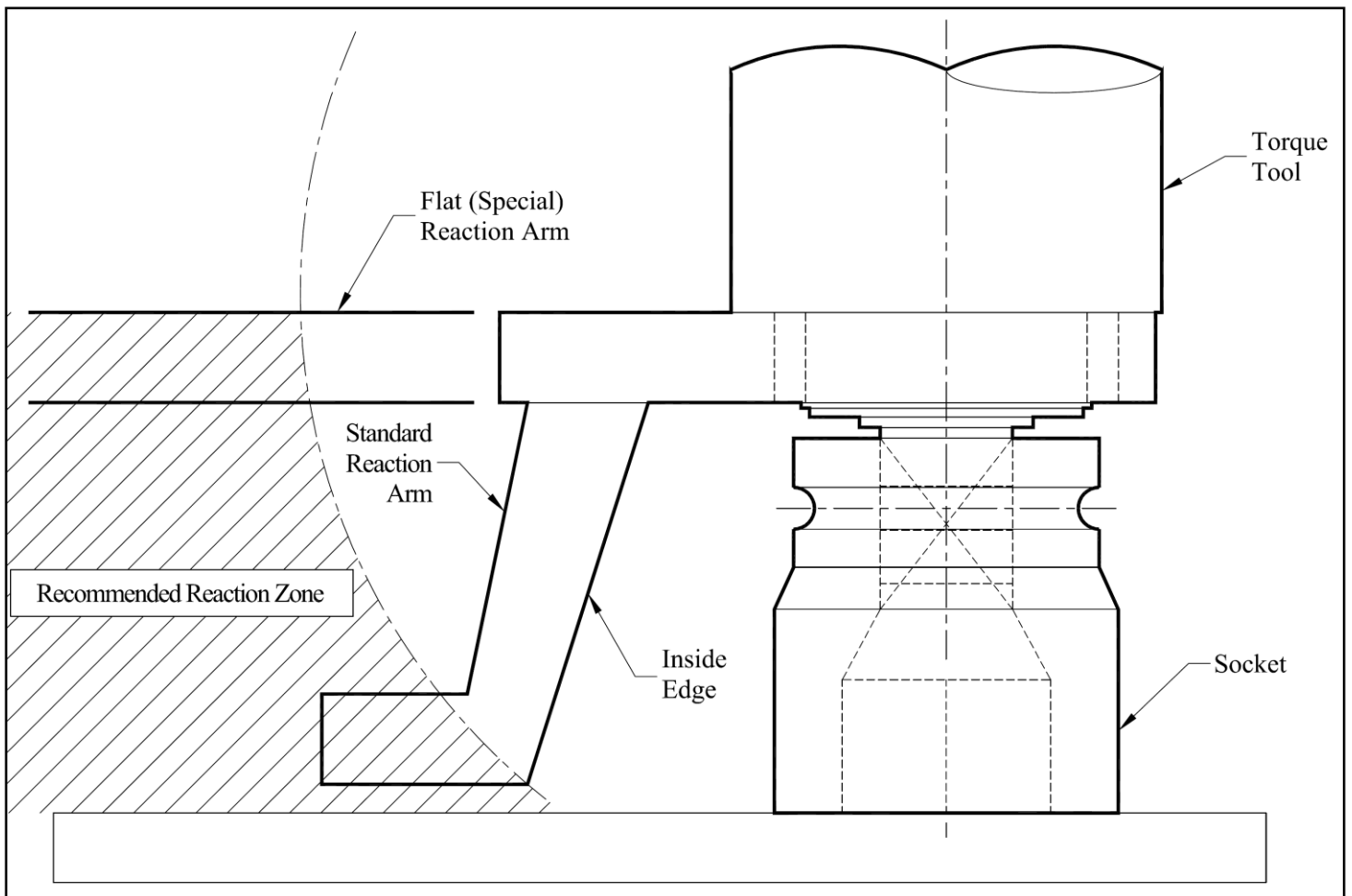

SETTING TORQUE FOR BOLT TIGHTENING

- 1) Ensure The battery pack and reserve battery are fully charged (see “Battery Charging” section)
- 2) Set the Direction Selector Switch (D) to forward.
- 3) Identify the torque required for the bolting application.
 - Change the target torque if the DB-RAD is not in the locked level (see “Change the Target Torque” section for details).
 - Select a Pre-set if it is in the Locked Level

SETTING TORQUE FOR BOLT LOOSENING

- 1) Set the Direction Selector Switch (D) to reverse.
- 2) Set the torque to maximum.
 - See “Change the Target Torque” section for details
 - Select the Highest Pre-set available if it is in the Locked Level



OPERATING THE WRENCH

- 1) Fit the wrench with the correct size impact socket to suit the bolt to be tightened and retain with ring and pin system
- 2) Rotate the handle to convenient position relative to the reaction arm.
- 3) Fit the tool onto the bolt to be tightened / un-tightened with the reaction arm adjacent to the reaction point (See “Torque Reaction” Section)
- 4) Move the Direction Selector Switch (D) from the neutral position and into either forward or reverse as required.
- 5) Squeeze the Trigger (C) to bring the reaction arm into contact with the reaction point.
- 6) Fully press the Trigger (C) and keep pressed until the clutch slips producing a pronounced ratcheting sound. When this happens release the Trigger (C) **Immediately**. If the trigger is released before the wrench clutch slips, full torque will not be applied to the bolt. Once the clutch slips do not “blip” the trigger, or incorrect torque will be applied. Damage to tooling will result if the clutch is allowed to slip for extended periods of time.
- 7) In use this tool must be supported at all times in order to prevent unexpected release of a fastener or component failure.
- 8) If during the un-tightening process the fastener does not release, and the clutch slips continuously, a tool of greater torque capacity must be used. Damage to tooling will result if the clutch is allowed to slip for extended periods of time.
- 9) If during tightening or un-tightening the tool stops rotating, but no ratcheting sound is heard from the clutch, the torque has **Not** been achieved. Release the trigger and replace or recharge the battery and re-tighten the fastener(s).
- 10) Remove tool from bolt.

IMPORTANT: For applications of a critical nature, DB-RAD wrenches must be torque checked daily.

If breakdown, malfunction or damage occurs do not attempt to repair, contact w.
Christie (Industrial) LTD immediately on +44 (0)1709 55 00 88

MAINTENANCE AND RECALIBRATION

To prevent premature failure and ensure confidence in torque supply, it is recommended that this equipment is serviced and calibrated at least on an annual basis, by W. Christie (Industrial) LTD.

There are no user serviceable parts. If any failures, breakdown, malfunction or damage occurs do not attempt to repair, contact W. Christie (Industrial) LTD immediately on +44 (0)1709 55 00 88

W. Christie (Industrial) LTD Offer a torque checking system (run down fixture) for sale or hire to monitor the torque output of all torque tools between annual calibration dates.

BATTERY CHARGING / CHANGING

- To remove the Battery Pack (B) from the DB-RAD wrench press the Battery Release button on the rear of the tool handle and pull the battery pack (B) from the Wrench.
- To install a new Battery Pack (B) to the DB-RAD wrench push the battery back into the wrench handle until it clicks in place.

NOTE: If the battery pack or charger appear damaged do not use

- Plug the Battery Charger (O) into an appropriate mains power supply (see charger base for voltage)
- Insert the Battery Pack (B) into the Battery Charger (O) (see figure below) ensure it is pushed fully home.

Temperature range for charging: 0°C - 50°C

Maximum charging cycles: 2,000

Charging Status Indicators (P) on the Battery Charger (O) show charging status

- Flashing green light – Battery is charging.
- Permanent green light – Battery is charged.
- Flashing red light – incorrect or defective battery.
- Permanent red light – battery too hot for charging.

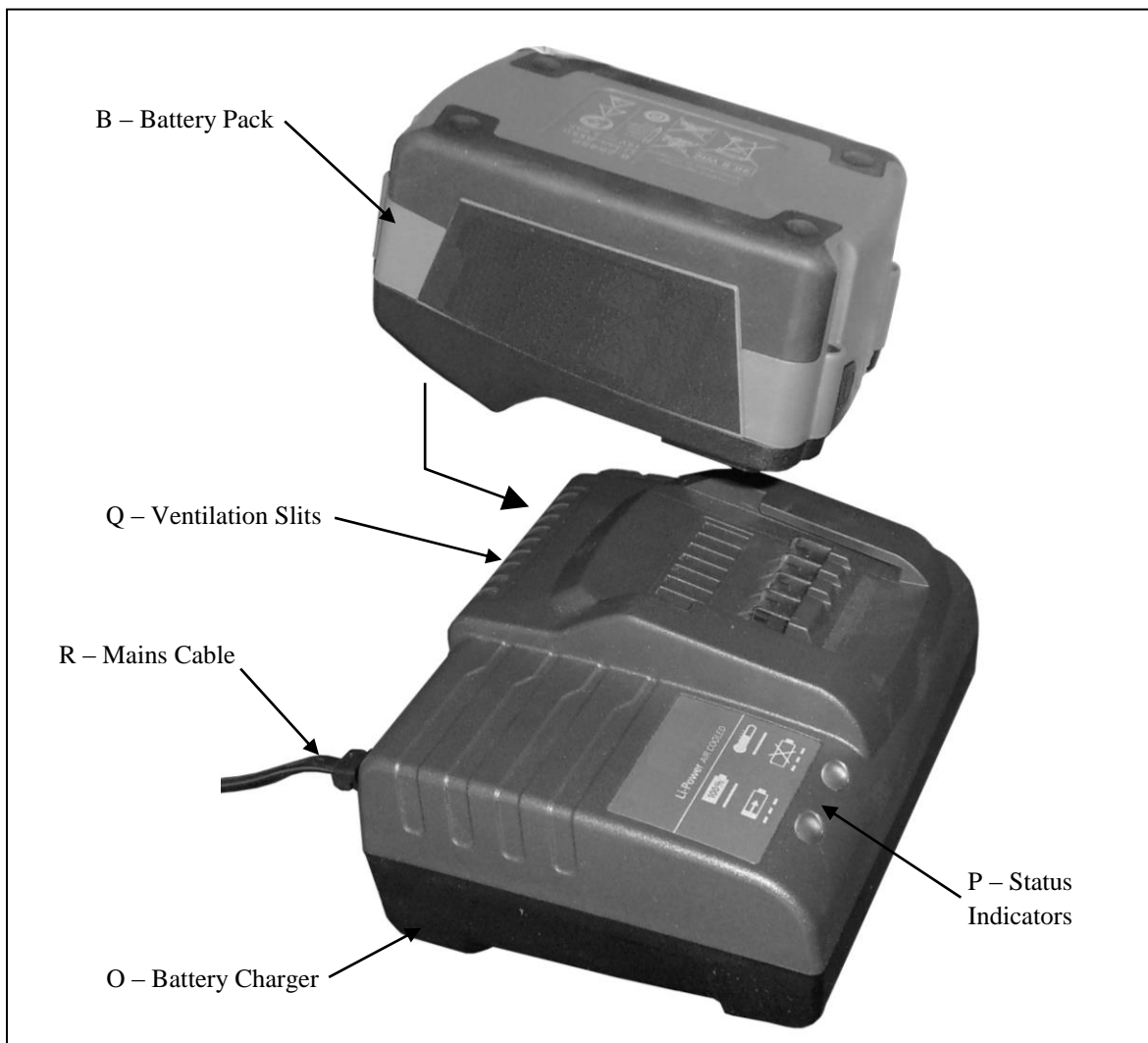



E.C. DECLARATION OF CONFORMITY

MODELS COVERED: DB-RAD 475, DB-RAD 700, DB-RAD 1400,
DB-RAD 2000

DESCRIPTION: Digital Battery Torque Wrench

We hereby declare that the following machinery complies with the essential health and safety requirements of the European Machinery Directive 2006/42/EC published on the 9th June 2006

W Christie (Industrial) Ltd, Meadowbank Road, Rotherham S61 2NF, United Kingdom.

This machinery has been designed and manufactured in accordance with the following transposed harmonised European Standard:-

BS EN ISO 12100-2:2003 Safety of Machinery – Technical Principles

BS EN 60745-1:2006 Hand-held Motor Operated Electric Tools – Safety – General Requirements

SIGNED: 

POSITION: Senior Applications Engineer

NAME: R. G. Askham

On behalf of W Christie (Industrial) Ltd

**HIRE
SERVICE**

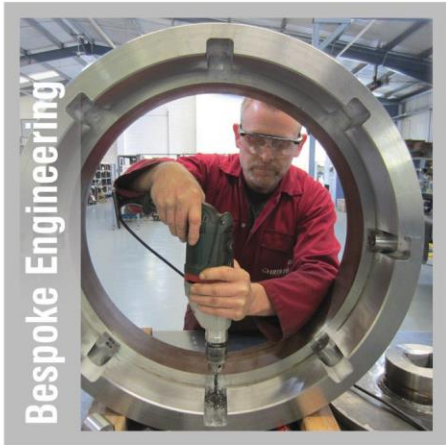

W. CHRISTIE (INDUSTRIAL) LTD
Christie House, Meadowbank Road,
Rotherham, South Yorkshire, S61 2NF

t: +44(0)1709 550088

e: info@wchristie.com

f: +44(0)1709 550030

w: www.wchristie.com



CHRISTIE
TOTAL TORQUE SOLUTIONS