

CE



**LOW (CASSETTE HEAD)
HYDRAULIC TOOL SERIES**

USER GUIDE



CONTENTS

<u>Page</u>	<u>Description</u>
1	Introduction
2	Assembly Connecting the Tool Torque Reaction
3	Bolt Tightening Bolt Tightening to Bolt Loosening Bolt Loosening If Tool Locks on Fastener
4	Head Removal and Replacement
5	Trouble Shooting Guide
6	E.C. Declaration of Conformity
--	Calibration Certificate

INTRODUCTION

IMPORTANT: -

BEFORE USING THIS TOOLING, ENSURE THESE OPERATING AND SAFETY INSTRUCTIONS ARE READ AND UNDERSTOOD, READ IN CONJUNCTION WITH THE APPROPRIATE POWER PACK OPERATING INSTRUCTION. IF BREAKDOWN OR MALFUNCTION OCCURS REPAIR SHOULD ONLY BE ATTEMPTED BY TRAINED PERSONNEL, IF IN DOUBT CONTACT W. CHRISTIE (INDUSTRIAL) LTD IMMEDIATELY.

LOW tools are reversible, non impacting, torque controlled bolt tightening and un-tightening tools designed to operate in a reciprocating action. (See figure 1)

They must always be used with the following:-

1. Clean hydraulic oil ISO32 or equivalent.
2. A suitable double acting hydraulic oil pump unit (low pressure return) capable of safely delivering 10,000 PSIG (700 Bar) hydraulic pressure.
3. Suitable hydraulic hoses and couplings capable of safely delivering 10,000 PSIG (700 Bar) hydraulic pressure, ideal safety factor 4:1.
4. Stable torque reaction.

Where the intended usage is not threaded fasteners, the safety and operation must be evaluated and appropriate precautions taken. Your distributor will be pleased to advise you.

These tools contain grease, which may cause an explosion in the presence of pure oxygen. Please contact your distributor for details of solutions to these hazards.

LOW Series, Low Profile Torque Wrenches – Figure 1

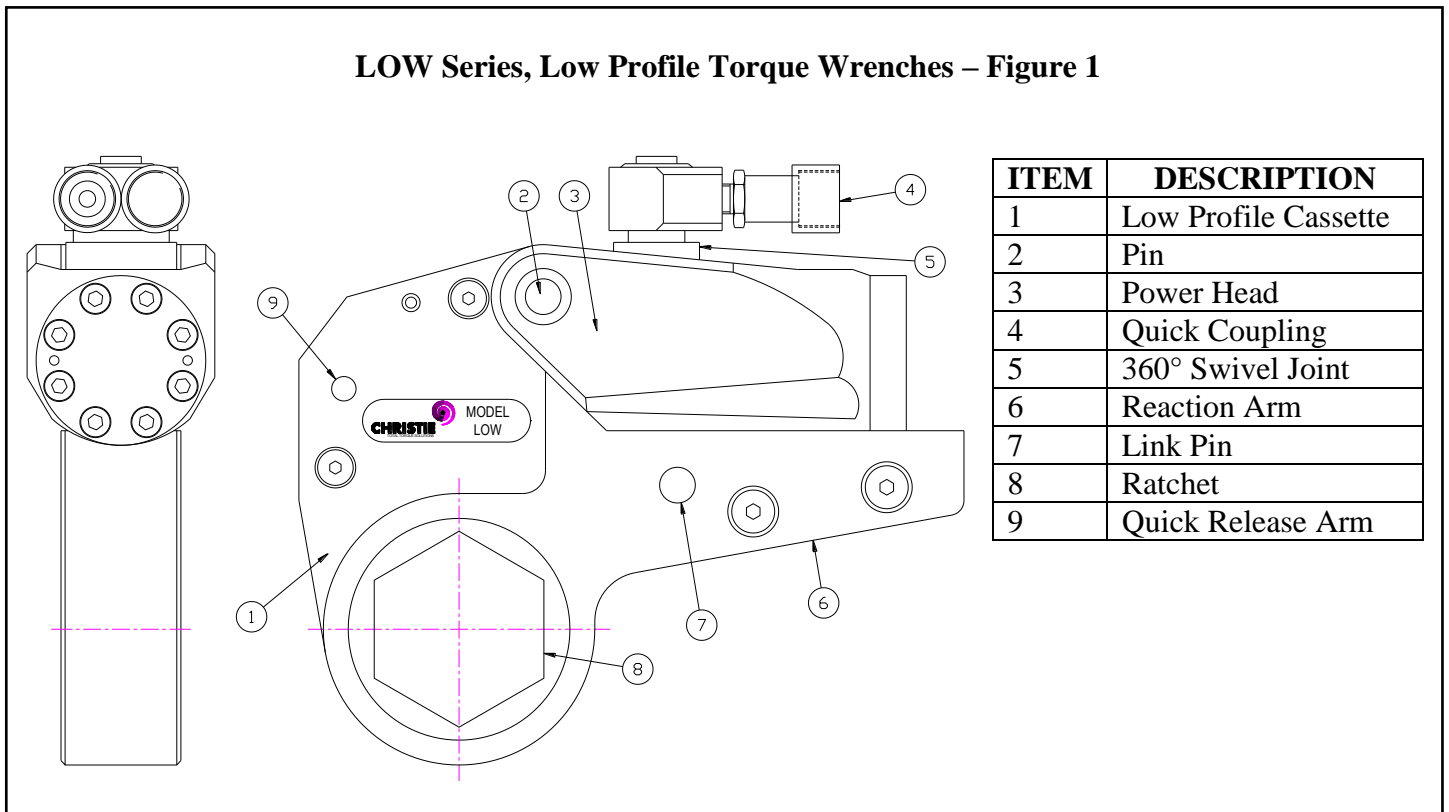

ASSEMBLY

- 1) Ensure:-
 - (i) The hydraulic ratchet fits comfortably on the application and there are no restrictions to the fastening operation.
 - (ii) The couplings on the ratchet and the pump units hoses are compatible and in clean and good condition.
- 2) Connect the pump unit's hoses to the couplings on the hydraulic ratchet ensuring the screw collar on each female coupling screws fully up to the shoulder on the male coupling

CONNECTING THE TOOL

The wrench and power pump are connected by a 700 BAR operating pressure, twin-line hose assembly. Each end of the hose will have one male and one female connector to assure proper interconnection between pump and wrench.

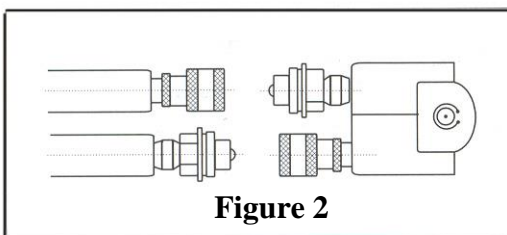

Ensure the connectors are fully engaged and screwed snugly and completely together.

TORQUE REACTION

When the wrench is in operation the reaction point rotates in the opposite direction to the output drive and must be allowed to rest squarely against a solid object or surface adjacent to the bolt to be tightened.

WARNING:- ALWAYS KEEP HANDS CLEAR OF THE REACTION POINT WHEN THE TOOL IS IN USE OR SERIOUS INJURY MAY RESULT.

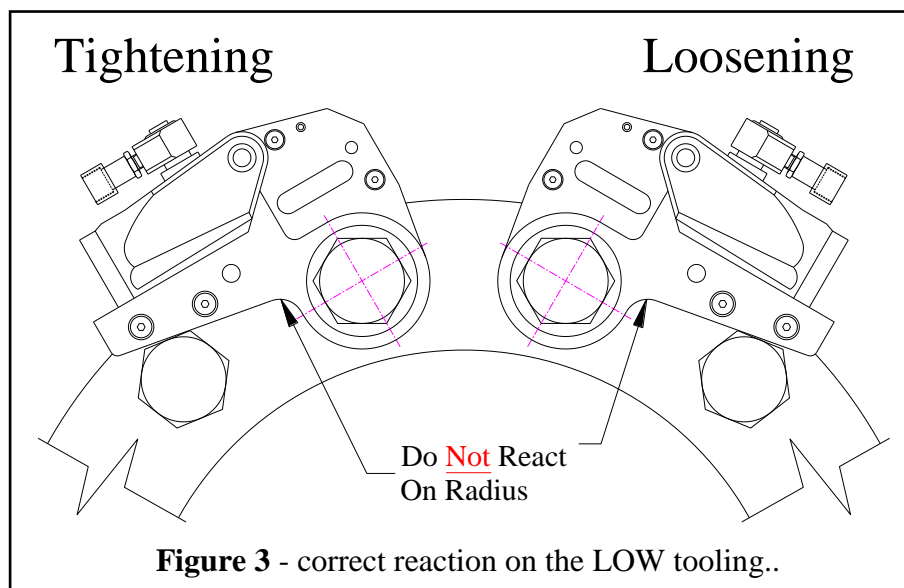

BOLT TIGHTENING

All tooling is supplied with a calibration chart relating torque output to hydraulic pressure.

- 1) Determine required hydraulic pressure for desired torque.
- 2) With hydraulic wrench free of its application, extend the cylinder.
- 3) When full stroke is achieved, maintain forward pressure and adjust to required setting by the relief valve on the pump unit, pressure increase or decrease will be indicated on the pump gauge.
- 4) Position the ratchet on its application, in the correct orientation for torque tightening; orientate reaction point on the tool to the chosen reaction object.

WARNING:- KEEP HANDS CLEAR OF REACTION POINT

- 5) Extend the cylinder until the forward stroke is complete. Retract cylinder, thus returning the ratchet to commence its next stroke.
- 6) The fastener is tight when the cylinder can no longer complete a full forward stroke.

NOTE:- A full stroke has been achieved when an audible click can be heard on the return stroke.

WARNING:- KEEP HANDS CLEAR OF REACTION POINT. AT NO TIME MUST THE COUPLINGS BE USED AS A REACTION POINT THIS IS EXTREMELY DANGEROUS. EXCEEDING THE MAXIMUM HYDRAULIC PRESSURE WILL OVERLOAD THE WRENCH AND MAY CAUSE SERIOUS DAMAGE.

BOLT TIGHTENING TO BOLT LOOSENING

To alternate from tightening to loosening the tool is turned over (see Figure 3).

BOLT LOOSENING

- 1) Establish maximum hydraulic pressure from calibration chart.
- 2) Set pressure as Bolt tightening, 2 and 3.
- 3) Position the ratchet on its application, in the correct orientation for de-torquing maintaining good reaction and socket location.
- 4) Extend the cylinder until the forward stroke is complete, retract cylinder, thus returning the ratchet to commence its next stroke.
- 5) Extend and retract the cylinder until the fastener is loose.

IF TOOL LOCKS ON FASTENER

During the operation, if the tool locks onto the nut, press advance button on the Power Pack's Pendant and build pressure-continue to press down on remote while pushing down on the reaction pawl. Release remote while continuing to push down on reaction pawl, then the tool will be released from the nut.

NOTE:- Fig 4 shows an exploded view of the mechanism with the reaction pawl situated behind the plate.

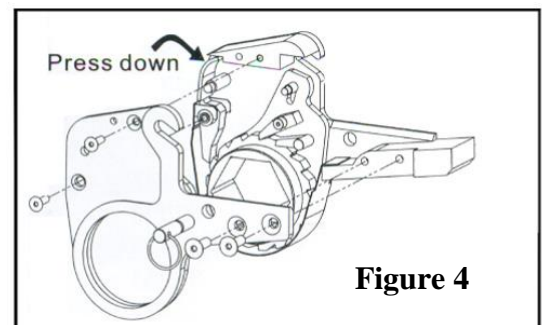

Figure 4

HEAD REMOVAL AND REPLACEMENT

The Power Head's drive arm is in the retracted position before connecting the link to the wrench head.

NOTE:- The 'Drive Arm' is the 'hook' that connects to the ratchet link's fixed pin.

DO NOT REMOVE THE FIXED PIN FROM THE WRENCH POWER HEAD.

The "hook" is inserted around the fixed pin of the power head and the link is swung down to rest along the base of the power lead cylinder.

At this point the link pin holes will align.

Insert the link pin to secure.

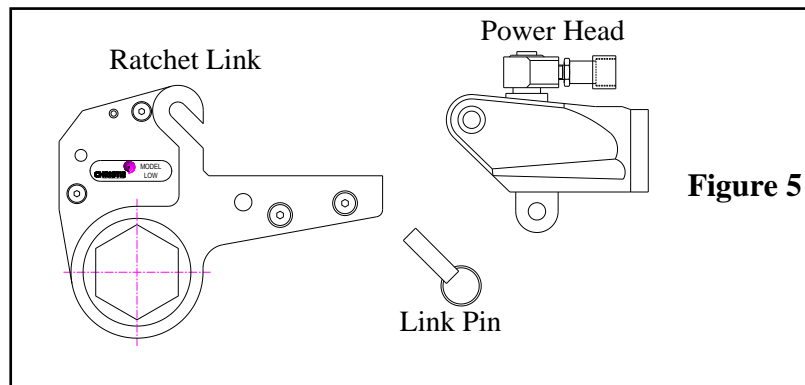

KEEP HANDS CLEAR OF REACTION POINT WHEN THE TOOL IS IN USE OR SERIOUS INJURY MAY RESULT.

AT ALL TIMES KEEP THE REACTION AS FAR AWAY AS POSSIBLE FROM THE OUTPUT DRIVE.

DO NOT EXTEND THE LENGTH OF THE REACTION ARM OR INDUCED SIDE LOAD MAY CAUSE TOOL DAMAGE.

AT NO TIME MUST THE COUPLINGS BE USED AS A REACTION POINT.

EXCEEDING THE MAXIMUM HYDRAULIC PRESSURE WILL OVERLOAD THE WRENCH AND MAY CAUSE SERIOUS DAMAGE.

UNDER NO CIRCUMSTANCES MUST A TOOL BE PRESSURISED WITH ONLY ONE HOSE CONNECTED.

SERIOUS DAMAGE MAY OCCUR IF:-

THE LOW TOOL IS USED WITHOUT FULL LOCATION ON THE FASTENER.

PERSONAL PROTECTION EQUIPMENT SHOULD BE WORN TO INCLUDE SAFETY GLASSES AND GLOVES.

TROUBLE SHOOTING GUIDE

TROUBLE	PROBABLE CAUSE	SOLUTION
Piston will not advance or retract	Couplers are not securely attached to the tool or pump	Check the coupler connections and make certain they are connected
	Coupler is defective	Replace the defective Coupler
	Defective remote control unit	Replace the button and/or control pendant
	Dirt in the direction-control valve or the pump unit	Disassemble the pump and clean the direction-control valve
Piston will not retract	Hose connections reversed	Make certain the advance on the pump is connected to the advance on the tool and retract on the pump is connected to the retract on the tool
	Retract hose not connected	Connect the retract hose securely
	Retract pin and/or spring broken	Replace the broken pin and/or spring
Cylinder will not build up pressure	Piston Seal and/or End Plug Seal leaking	Replace any defective o-ring
	Coupler is defective	Replace any defective Coupler
Drive will not turn	Grease or dirt built up in the teeth of the Ratchet and Segment Pawl	Disassemble the Ratchet and clean the grease or dirt out of the teeth
	Worn or broken teeth on Ratchet and/or Segment Pawl	Replace any worn or damaged parts
Pump will not build up pressure	Defective relief valve	Inspect, adjust or replace the relief valve
	Electric power source is too low	Make certain the amperage, voltage and any extension cord size comply with the pump manual requirements
	Defective Gauge	Replace the Gauge
	Low oil level	Check and fill the pump reservoir
	Clogged filter	Inspect, clean and/or replace the pump filter



E.C. DECLARATION OF CONFORMITY

MODELS COVERED: 2LOW, 4LOW, 8LOW, 14LOW, 30LOW

DESCRIPTION: LOW (Cassette Head) Hydraulic Tool Series

We hereby declare that the following machinery complies with the essential health and safety requirements of the European Machinery Directive 2006/42/EC published on the 9th June 2006

W Christie (Industrial) Ltd, Meadowbank Road, Rotherham S61 2NF, United Kingdom.

This machinery has been designed and manufactured in accordance with the following transposed harmonised European Standard:-

BS EN ISO 12100-2:2003 Safety of Machinery – Technical Principles

SIGNED: 

NAME: R. G. Askham

POSITION: Senior Applications Engineer

On behalf of W Christie (Industrial) Ltd



W. CHRISTIE (INDUSTRIAL) LTD
Christie House, Meadowbank Road,
Rotherham, South Yorkshire, S61 2NF
t: +44(0)1709 550088
e: info@wchristie.com
f: +44(0)1709 550030
w: www.wchristie.com



CHRISTIE
TOTAL TORQUE SOLUTIONS