

LH

Hydraulic Torque Tool

Low Height (LH) hydraulic torque tooling solves the problem of limited height access on flange fitting and maintenance by making the reaction point sit firmly on the rim of the flange.

HIRE, SALES & ADVICE
01709 550088

LH HYDRAULIC

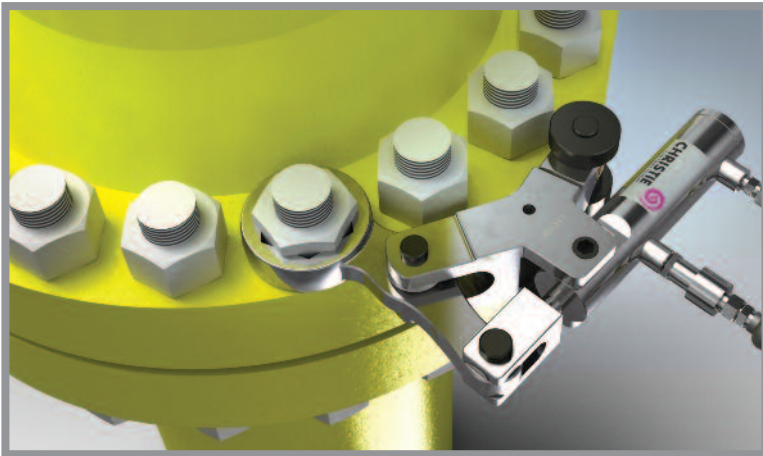
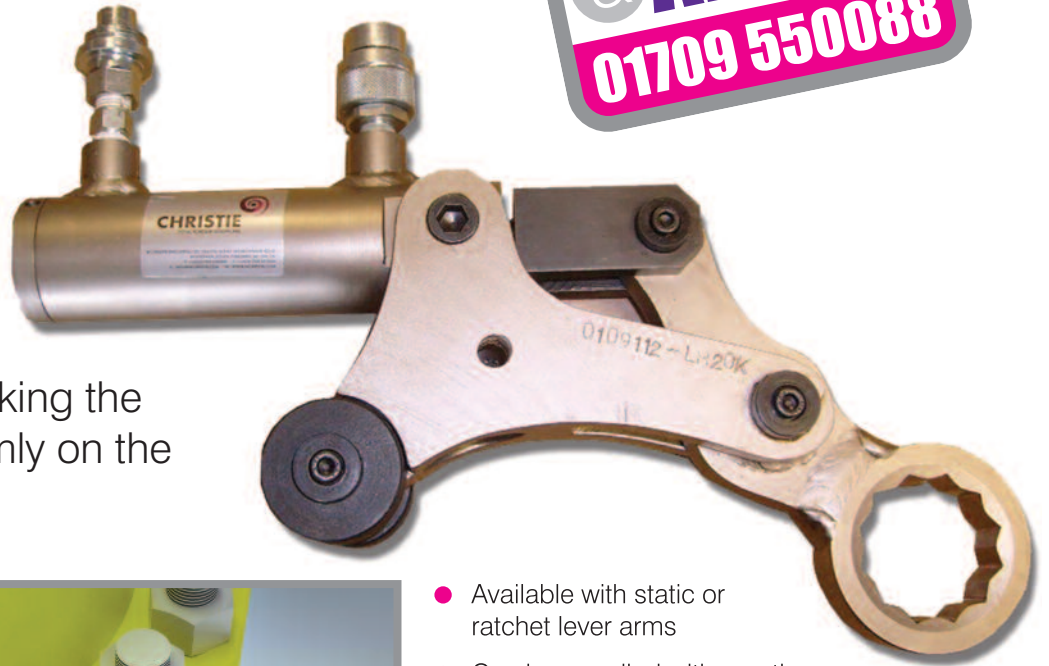

- Available with static or ratchet lever arms
- Can be supplied with reaction arms up to 120mm across flats
- Lever arms can be built to specific applications

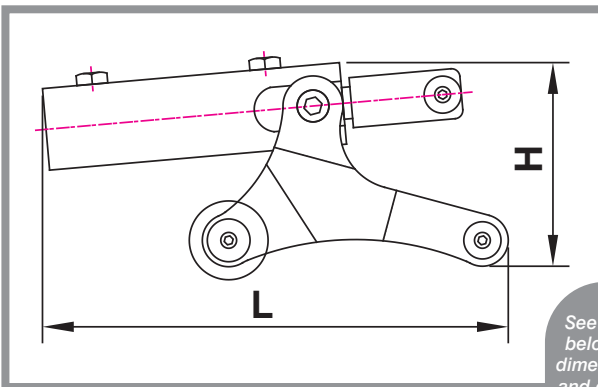

See table below for dimensions and details

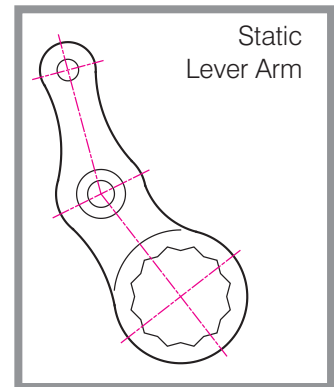
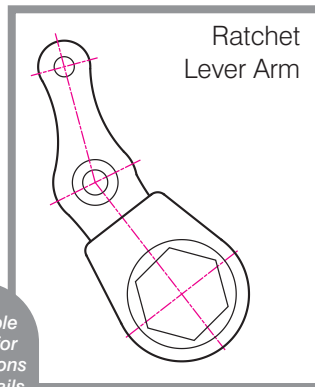

Model	Dimensions		Weight Kg	Max. A/F		Torque Capacity Nm	Max. Operating Pressure Psi
	H mm	L mm		Ins.	mm		
LH20K	127	280	6.5	2"	51	2,720	10,000
LH30K	140	304	9	2¾"	70	7,400	10,000
LH60K	152	330	14	3½"	90	14,800	10,000
LH100K	216	381	26	4⅝"	120	24,000	10,000