

VC-RAD 31 ELECTRIC TORQUE MULTIPLIER – TECHNICAL DATA

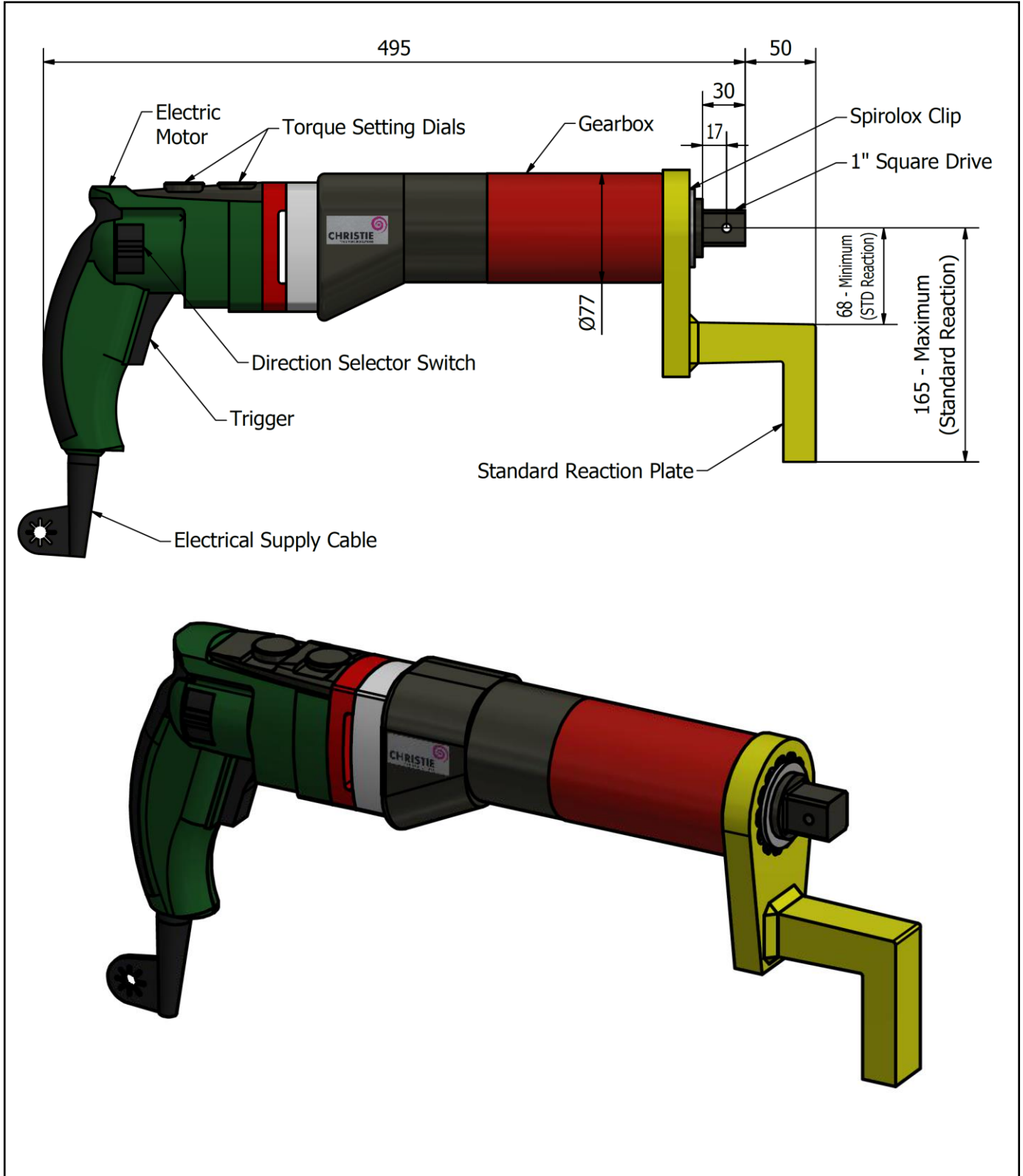

VC-RAD 31 ELECTRIC TORQUE MULTIPLIER – TECHNICAL DATA

DESCRIPTION

The VC-RAD 31 Electric Torque Multiplier is a hand held, non-impacting electrically driven power tool designed to apply torque to tighten and remove threaded fasteners.

The reaction force works in the opposite direction to the applied torque. The point of reaction should be kept as far away as practicable from the centre of the gearbox to minimise this force.

Torque is controlled by adjusting the torque setting dials. Corresponding settings and torques are determined using the calibration certificate provided.

The VC-RAD 31 must always be operated with the following:-

- 110v or 240v Electrical Supply (Dependant on model purchased)
- Impact Quality Sockets
- Reaction Arm

SPECIFICATION

Output Square Drive (Male):	1" (25.4mm)
Direction:	Forward & Reverse
Torque Accuracy:	+/- 10%
Minimum Output Torque:	1,100 Nm (811 lbf.ft)
Maximum Output Torque:	3,100 Nm (2,286 lbf.ft)
Speed:	4 rpm (Single)
Power Supply Voltage:	110V or 240V (dependant on model purchased)
Electric Motor Input Power:	850 Watts
Electric Motor Output Power:	480 Watts
Noise:	Less than 80 dB(A)
Vibration:	Vibration level at handle does not exceed 2.5m/sec
Tool Weight:	7.6 Kg (16.76 lbs)
Reaction Plate Weight:	2.04 Kg (4.5 lbs)

ACCESSORIES AVAILABLE

The following accessories are available upon request and can be custom made to suit requirements. Please contact W. Christie (Industrial) Limited for more information:-

- Special Reactions
- Nose Cone Extensions
- Offset Gearbox
- Impact Quality Sockets
- Torque Checking System (Rundown Fixture)

No statement or data within this literature is warranted or guaranteed to be accurate.



W. CHRISTIE (INDUSTRIAL) LTD
CHRISTIE HOUSE
MEADOWBANK ROAD
ROTHERHAM
SOUTH YORKSHIRE
S61 2NF UK
T: +44(0)1709 550088 F: +44(0)1709 550030
E: INFO@WCHRISTIE.COM W: WWW.WCHRISTIE.COM