

## VC-RAD 40 SELECT ELECTRIC TORQUE WRENCH – TECHNICAL DATA

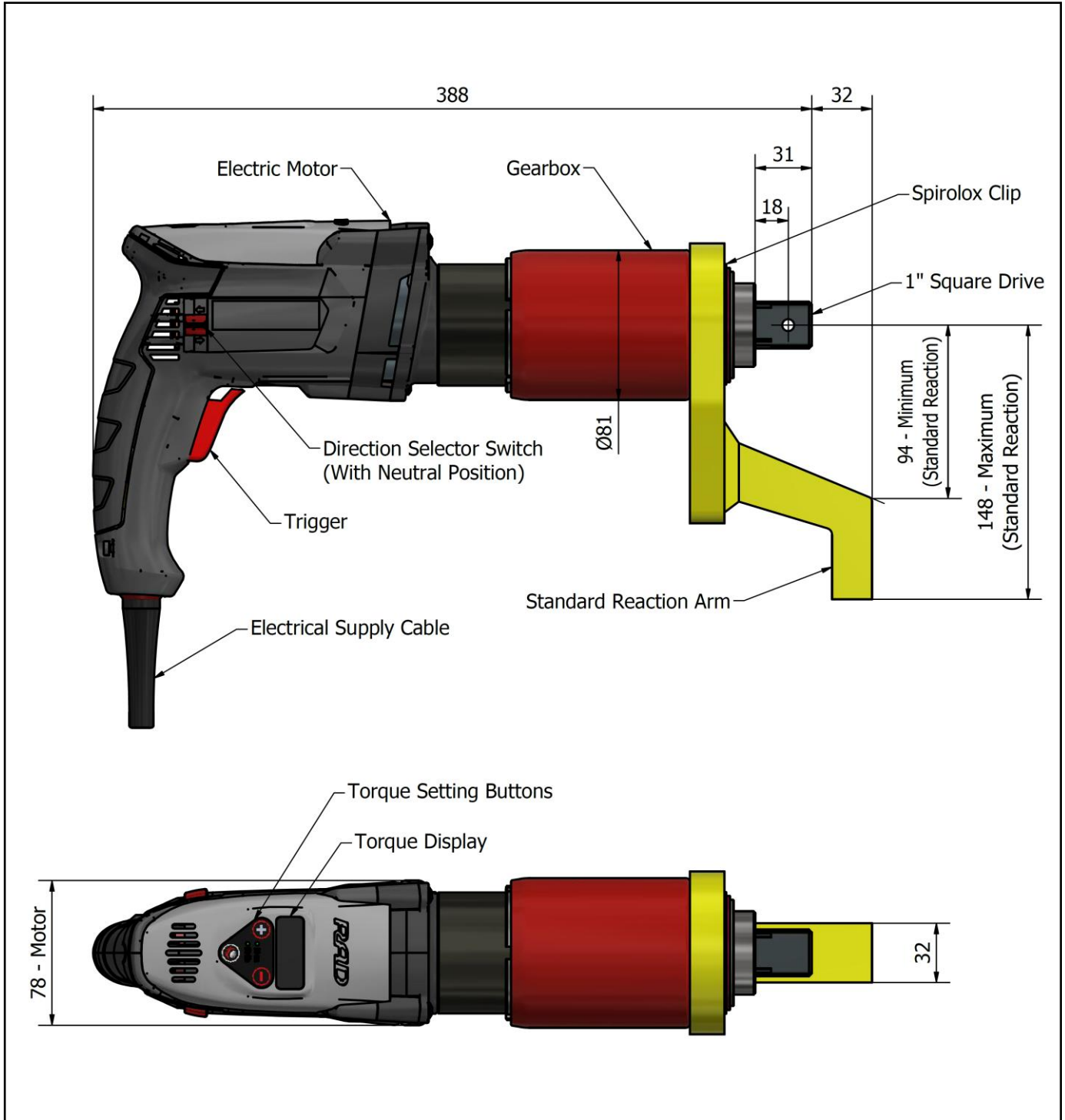

# VC-RAD 40 SELECT

## ELECTRIC TORQUE WRENCH – TECHNICAL DATA

### DESCRIPTION

The VC-RAD 40 Select Electric Torque Wrench is a hand held, non-impacting electrically driven power tool designed to apply torque to tighten and remove threaded fasteners.

The reaction force works in the opposite direction to the applied torque. The point of reaction should be kept as far away as practicable from the centre of the gearbox to minimise this force.

Torque is controlled by the torque setting buttons. The torque figure is displayed on the torque display.

The VC-RAD 40 Select must always be operated with the following:-

- 110v or 240v Electrical Supply (Dependant on model purchased)
- Impact Quality Sockets
- Reaction Arm

### SPECIFICATION

Output Square Drive (Male):	1" (25.4mm)
Direction:	Forward & Reverse
Torque Accuracy:	+/- 5%
Minimum Output Torque:	400 Nm (300 lbf.ft)
Maximum Output Torque:	4,000 Nm (3,000 lbf.ft)
Speed:	2.7 rpm (Single)
Power Supply Voltage:	110V or 240V (dependant on model purchased)
Noise:	Less than 85 dB(A)
Vibration:	Vibration level at handle does not exceed 2.5m/sec
Tool Weight:	6.2 Kg (13.67 lbs)
Reaction Plate Weight:	2 Kg (4.4 lbs)

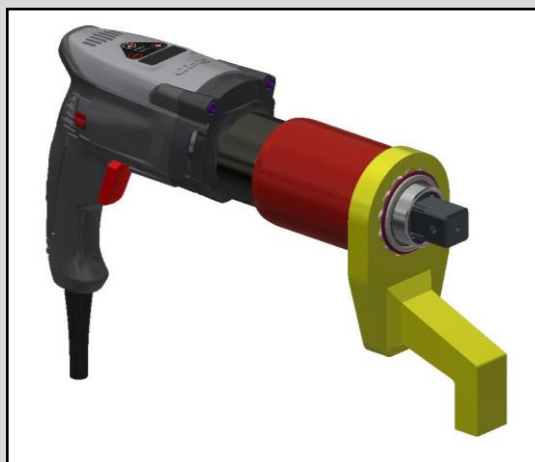

### ACCESSORIES AVAILABLE

The following accessories are available upon request and can be custom made to suit requirements. Please contact W. Christie (Industrial) Limited for more information:-

- Special Reactions
- Nose Cone Extensions
- Offset Gearbox
- Impact Quality Sockets
- Torque Checking System (Rundown Fixture)

No statement or data within this literature is warranted or guaranteed to be accurate.