

DIMENSIONS REQUIRED

NUMBER OF BOLTS:	E=
A= <i>ACROSS FLATS</i>	F=
B=	G=
C= <i>PITCH CIRCLE RADIUS</i>	H=
D=	I=

MAXIMUM TORQUE REQUIRED

Nm
LBF.FT

EACH GEARED OFFSET IS MANUFACTURED TO CUSTOMERS SPECIFICATIONS, THEREFORE ITS IS ESSENTIAL THAT W. CHRISTIE OBTAIN AS MUCH INFORMATION AS POSSIBLE. PLEASE COMPLETE THE DIAGRAM AND RETURN TO W. CHRISTIE

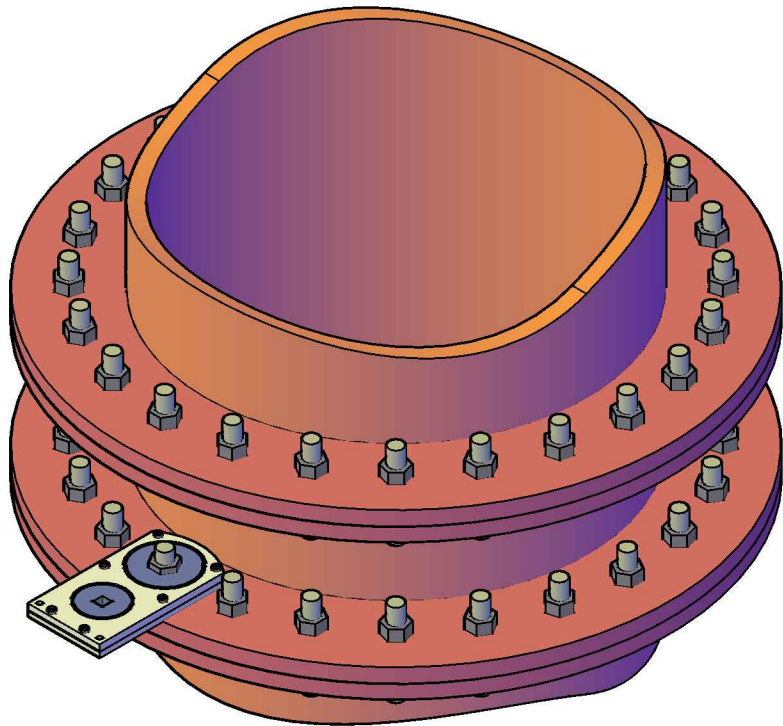
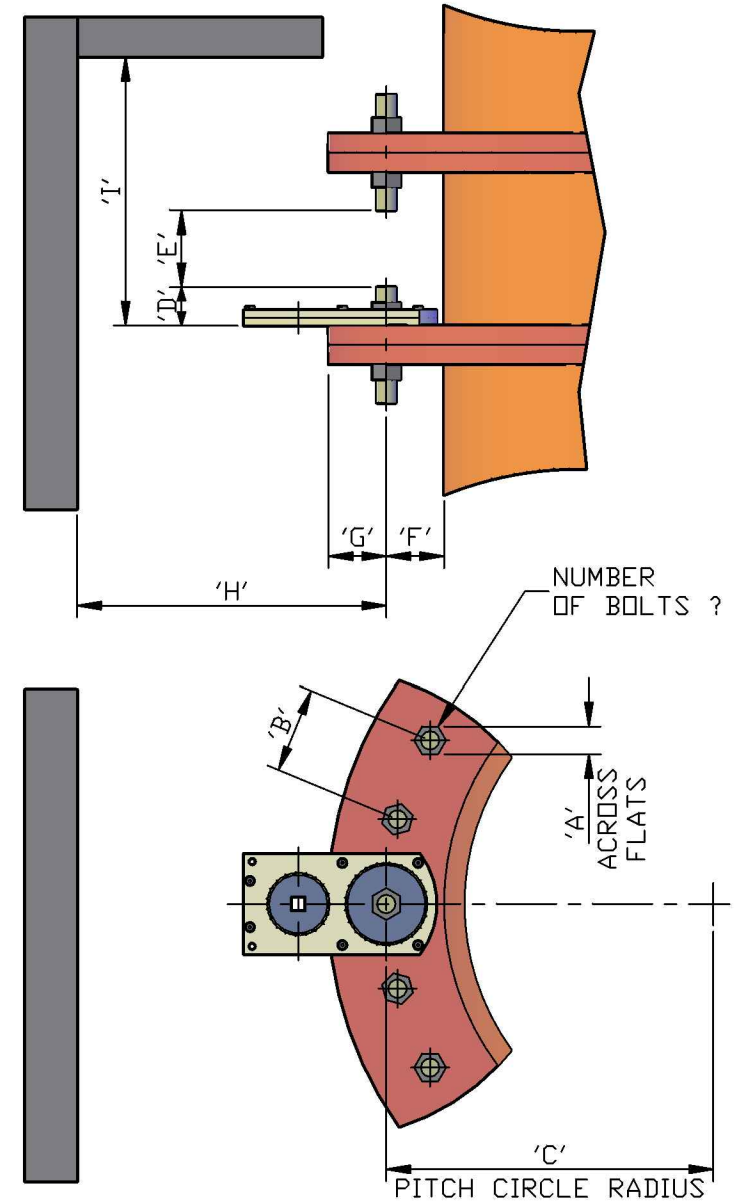

OFFSET GEARBOX
SITE QUESTIONNAIRE

TITLE: OFFSET GEARBOX SITE QUESTIONNAIRE

MATERIAL / FINISH:

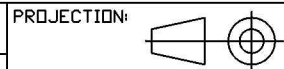

DRAWN:
P Richardson

DATE:
20-06-07

SCALE:
N.T.S.

HEAT TREATMENT:

APPROVED:
S Porter

DRAWING: No:
3-10030 SHT1

REVISION:
0

JOB No:



CHRISTIE HOUSE
MEADOWBANK ROAD
ROTHERHAM
S61 2NF
TEL: +44 (0)1709 550088
FAX: +44 (0)1709 550030
E-MAIL: INFO@WCHRISTIE.COM