



C-RAD Remote

Pneumatic Torque Tool

- Remotely operated
- Non-impacting
- Low noise (operates below 85 decibels)
- Accurate (will stall repeatedly within +/- 4%)
- Alternative, top and rear air inlet ports
- Auto two speeds available*
- All tools supplied with a dedicated calibration certificate

See table below for dimensions and detail



Model	Dimensions (mm)			Weight Kg	Speed (rpm)		Torque Range (Nm)		Square Drive
	A	B	C		Single	Auto 2	Min	Max	
C-RAD 1 R	202	62	89	3.2	290	n/a	20	100	3/4"
C-RAD 3 R	208	62	89	3.3	90	n/a	50	275	3/4"
C-RAD 5 R	216	62	89	3.4	55	n/a	80	500	3/4"
C-RAD 5A R	275	62	89	4.7	n/a	250	150	500	3/4"
C-RAD 10L R	253	63	89	4.2	30	n/a	150	950	3/4"
C-RAD 14 R	253	63	89	4.3	12	n/a	275	1,350	3/4"
C-RAD 14A R	304	63	89	5.2	n/a	80	400	1,350	3/4"
C-RAD 20 R	254	69	89	4.6	10	n/a	400	2,000	1"
C-RAD 20A R	309	69	89	5.5	n/a	50	700	2,000	1"
C-RAD 27 R	~290	76	~120	6.7	10	n/a	550	2,700	1"
C-RAD 27A R	~342	76	~120	8.3	n/a	45	850	2,700	1"
C-RAD 34 R	~311	77	~120	7.5	8.5	n/a	700	3,400	1"
C-RAD 34A R	~360	77	~120	8.6	n/a	35	952	3,400	1"
C-RAD 40DX R	~314	81	~120	8.0	6	n/a	1,200	4,000	1"
C-RAD 40DXA R	~393	81	~120	8.3	n/a	49	1,400	4,000	1"
C-RAD 46 R	357	86	~120	11.0	12	n/a	1,360	4,600	1"
C-RAD 70 R	~355	95	~120	11.7	4.5	n/a	2,000	7,000	1 1/2"
C-RAD 80 R	~365	102	~120	13.5	6.6	n/a	2,700	8,000	1 1/2"
C-RAD 110 R	~501	115	~120	14.8	4	n/a	3,400	10,800	1 1/2"
C-RAD 115 R	~450	115	~120	18.4	4.5	n/a	4,100	11,500	1 1/2"
C-RAD 150 R	~440	127	~120	20.0	3	n/a	5,400	15,000	1 1/2"

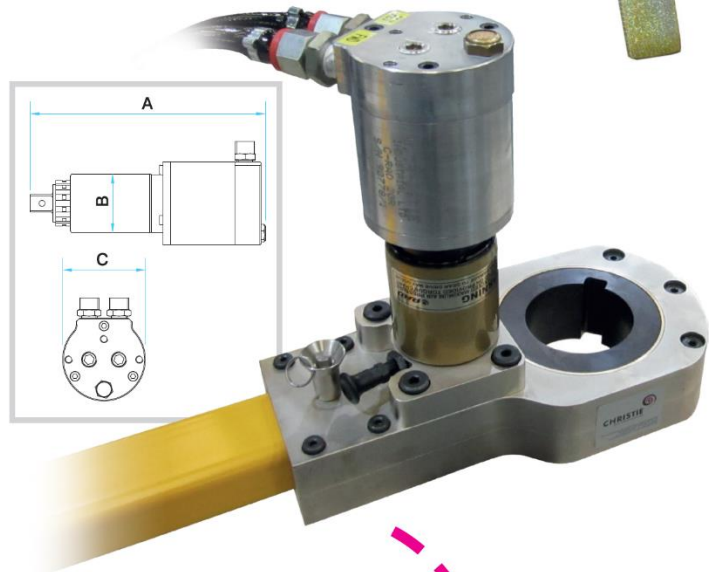
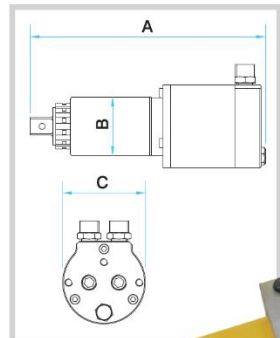

* 'A' denotes Auto 2 Speed models



C-RAD 14 R with Remote Lubro Control Unit connected via rear air inlets

HIRE, SALES & ADVICE
01709 550088