

CE



CHRISTIE
TOTAL TORQUE SOLUTIONS

EDR70X-LPR POWER PACK (ELECTRIC)

USER GUIDE



CONTENTS

<u>Page</u>	<u>Description</u>
1	Introduction Specification Accessories Available
2	Power Pack Features
3	Operating Instructions
4	Safety
5	Power Pack Parts List
6	Hydraulic Hose Parts List
7	Fault Finding
8	E.C. Declaration of Conformity

INTRODUCTION

The EDR70X-LPR power pack is a portable, electrically actuated, double acting, “Xtra” pump with a low pressure return.

The Christie range of power packs are the toughest on the market, combining effortless power with supreme performance.

The power pack is supplied complete with one control pendant / cable assembly and two hydraulic hose assemblies.

The unit is operated using the two button control pendant.

SPECIFICATION

Electrical Supply Options (In):	110v 1PH / 240v 1PH / 415v 3PH
Maximum Hydraulic Pressure (Out):	690 bar (10,000 psi)
Pressure Gauge Units:	psi or bar
Flow Stage 1 (Out):	10 litres/minute (0.353 cfm)
Flow Stage 2 (Out):	1 litres/minute (0.0353 cfm)
Oil Reservoir Capacity:	7 Litres (427.17 in ³)
Hydraulic Hoses Length:	4m
Total Weight (Excluding Hoses):	~41 Kg (90.39 lb)
Noise:	Less than 85 dB(A)
Hydraulic Port Size:	1/4" NPT

ACCESSORIES AVAILABLE

The following accessories are available upon request and can be custom made to suit requirements. Please contact W. Christie (Industrial) Limited for more information:-

- Extra Length hoses
- Protective storage case
- Portable trolley



POWER PACK FEATURES

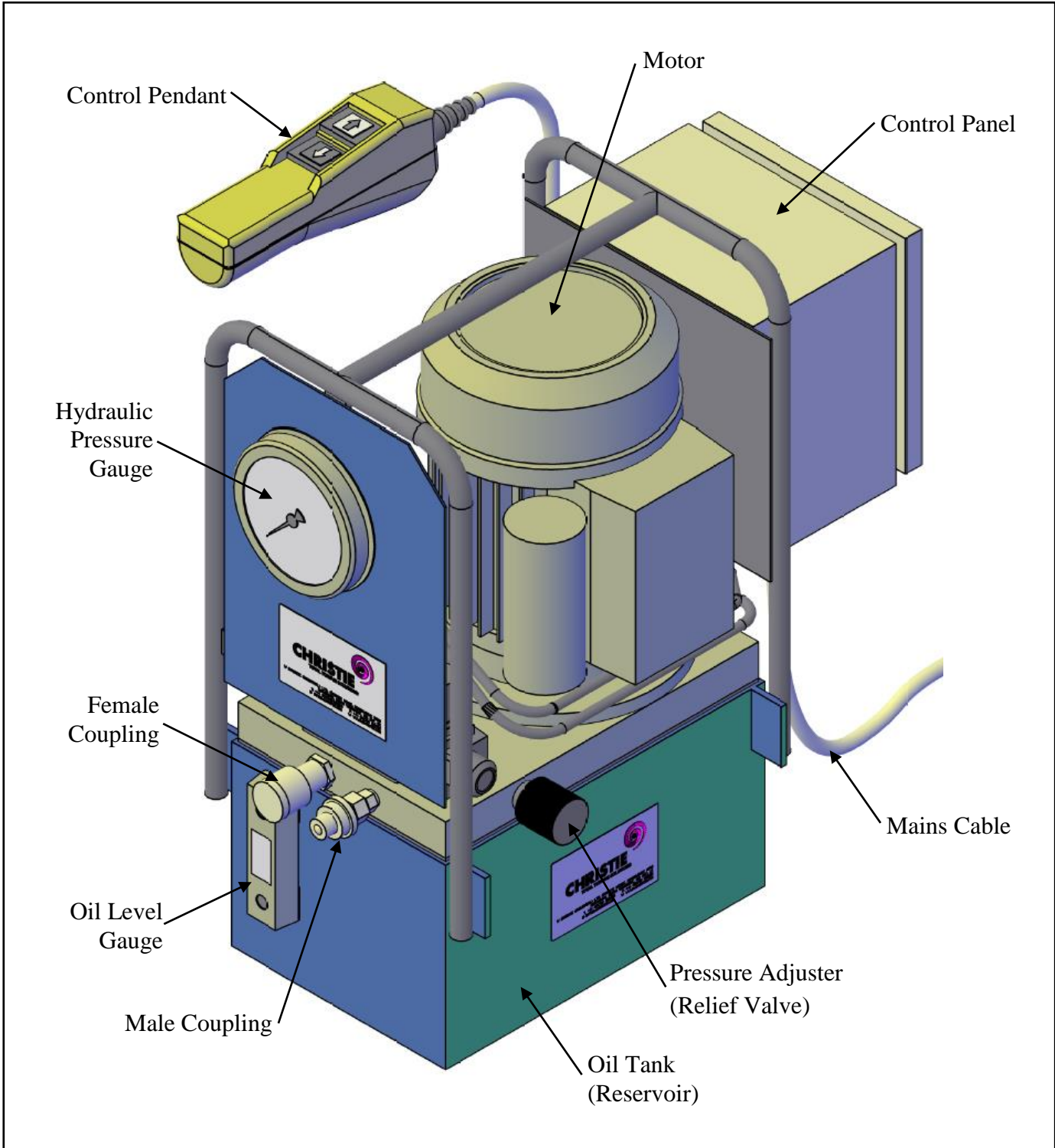

OPERATING INSTRUCTIONS

IMPORTANT: DO NOT OPERATE THIS TOOLING BEFORE THE OPERATING AND SAFETY INSTRUCTIONS ARE READ AND UNDERSTOOD.

IF BREAKDOWN, MALFUNCTION OR DAMAGE OCCURS DO NOT ATTEMPT TO REPAIR, CONTACT W. CHRISTIE (INDUSTRIAL) LTD IMMEDIATELY.

Before using the power pack electric unit ensure:-

1. The operating and safety instructions are read and understood.
2. The relief valve, located on the side of the unit is fully unwound (anti-clockwise)
3. Tank is filled with oil (Tellus 32 or equivalent).
4. Electric power supply is correct (110V or 240V).
5. Couplings are clean and fully engaged.
6. Connect hoses to the hydraulic tooling to be operated (see relevant operating instructions).
7. Start the pump running by pressing the 'on' button on the back of the control panel.
8. Depress the white button on the hand pendant.
9. Slowly rotate the relief valve, cylinder will extend.

Note: If cylinder does not extend, depress the black pendant button. Hydraulic pressure will register on the gauge

10. Adjust the hydraulic pressure to the required setting using the relief valve on the outside of the unit.
11. With pressure set, the power pack is now ready for use.

Note: This is a double acting pump unit, depressing the pendant control buttons will extend or retract a cylinder. Which button extends and which button retracts is dependant on hose orientation.

SAFETY

1. The incorrect use of hydraulic equipment is dangerous. Ensure that personnel familiarise themselves with the operating instructions.
2. Operating personnel should be safely and correctly attired i.e. safety glasses, safety boots, industrial gloves and overalls.
3. If more than one engineer is involved in the operation of torque machinery, good communication must be established to prevent accidents or misunderstandings.
4. Do not use electrical cables to tow the power pack.
5. **NEVER** exceed the maximum working pressure of hydraulic equipment.
6. Before use check pneumatic and hydraulic hoses are not cut, split, kinked or damaged. If in doubt do not use.
7. Do not hold the hoses when they are pressurised, especially on the swagings. Hose failure may lead to serious injury.
8. If any leaks are detected whilst the pump is in operation, stop using it immediately. Contact W. Christie (Industrial) Ltd for guidance.
9. Take care not to stand on or run over hydraulic hoses or air lines. To minimise danger ensure that these lines are not run across walkways, ladders, roadways and doorways and that people likely to pass through the working area are aware of the danger.
10. Maintenance guidelines should be strictly adhered to, poor equipment may lead to component failure and injury.
11. **NEVER** pressurise a hose or cylinder leaving the coupling at the other end disconnected. If this coupling fails serious or fatal injury may result.
12. The pump unit contains aluminium and magnesium; this makes it unsuitable for use in certain industries i.e. mining and petrochemical. For guidance contact W. Christie (Industrial) Ltd.
13. A power pack should never be used without a motor silencer fitted, noise may cause damage to hearing.
14. No work should be undertaken by personnel unfamiliar with the hydraulic system. In the event of the breakdown, contact W. Christie (Industrial) Ltd.

POWER PACK PARTS LIST

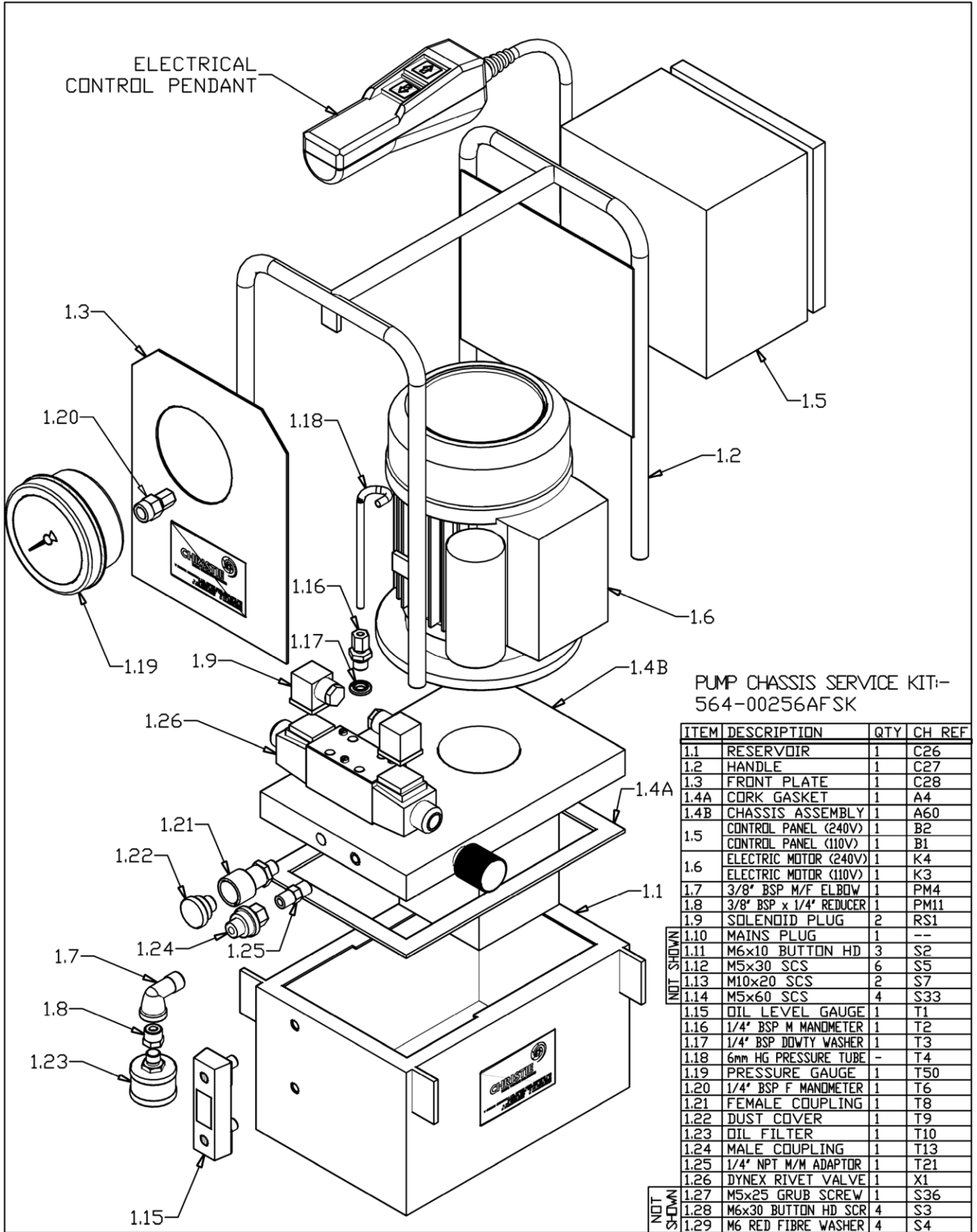

PUMP CHASSIS SERVICE KIT:-
564-00256AFSK

ITEM	DESCRIPTION	QTY	CH REF
1.1	RESERVOIR	1	C26
1.2	HANDLE	1	C27
1.3	FRONT PLATE	1	C28
1.4A	CDRK GASKET	1	A4
1.4B	CHASSIS ASSEMBLY	1	A60
1.5	CONTRL PANEL (240V)	1	B2
	CONTRL PANEL (110V)	1	B1
1.6	ELECTRIC MOTOR (240V)	1	K4
	ELECTRIC MOTOR (110V)	1	K3
1.7	3/8" BSP M/F ELBOW	1	PM4
1.8	3/8" BSP x 1/4" REDUCER	1	PM11
1.9	SOLENOID PLUG	2	RS1
1.10	MAINS PLUG	1	--
1.11	M6x10 BUTTON HD	3	S2
1.12	M5x30 SCS	6	S5
1.13	M10x20 SCS	2	S7
1.14	M5x60 SCS	4	S33
1.15	DIL LEVEL GAUGE	1	T1
1.16	1/4" BSP M MANDMETER	1	T2
1.17	1/4" BSP DOWTY WASHER	1	T3
1.18	6mm HG PRESSURE TUBE	-	T4
1.19	PRESSURE GAUGE	1	T50
1.20	1/4" BSP F MANDMETER	1	T6
1.21	FEMALE COUPLING	1	T8
1.22	DUST COVER	1	T9
1.23	DIL FILTER	1	T10
1.24	MALE COUPLING	1	T13
1.25	1/4" NPT M/M ADAPTOR	1	T21
1.26	DYNEX RIVET VALVE	1	X1
1.27	M5x25 GRUB SCREW	1	S36
1.28	M6x30 BUTTON HD SCR	4	S3
1.29	M6 RED FIBRE WASHER	4	S4

HYDRAULIC HOSE PARTS LIST

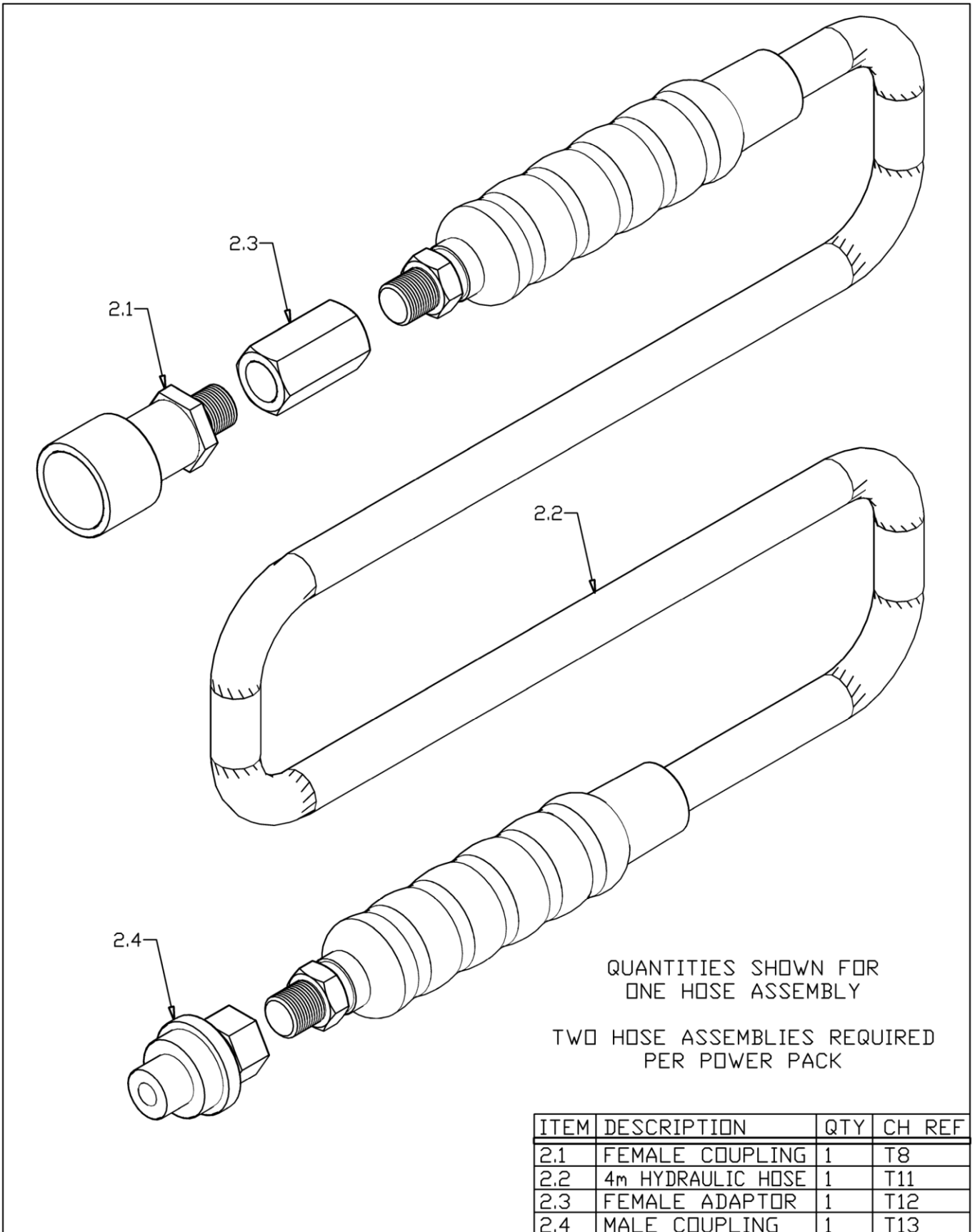

FAULT FINDING

FAULT	POSSIBLE CAUSE	SOLUTION
Motor will not run.	<ul style="list-style-type: none"> • No supply to the pump • Pump not switched on • Control panel tripped • Motor / electrical fault 	<ul style="list-style-type: none"> • Check supply • Switch on • Reset Trips • Contact W.Christie (Industrial) Ltd
Motor runs but no pressure visible on gauge.	<ul style="list-style-type: none"> • Low oil level • Relief valve backed off • Piston block defective • Filter blocked • Pump defective 	<ul style="list-style-type: none"> • Top up • Adjust • Replace • Replace • Replace
Motor runs but slow to reach pressure.	<ul style="list-style-type: none"> • Relief valve defective / backed off • Piston block defective • Pump defective 	<ul style="list-style-type: none"> • Clean / replace / adjust • Replace • Replace
Pump runs but attached tool slow or no movement.	<ul style="list-style-type: none"> • Relief valve backed off / defective • Couplings not fully tightened • Defective coupling • Defective tool 	<ul style="list-style-type: none"> • Clean / replace / adjust • Tighten Correctly • Replace • Check tooling
Pump will only operate in one direction	<ul style="list-style-type: none"> • Couplings not tightened fully / defective • Solenoid / electrical fault • Solenoid valve defective 	<ul style="list-style-type: none"> • Tighten / replace • Investigate • Replace



E.C. DECLARATION OF CONFORMITY

MODEL COVERED: EDR70X-LPR

DESCRIPTION: Portable, Electrically Actuated, Double Acting
Xtra Power Pack

We hereby declare that the following machinery complies with the essential health and safety requirements of the European Machinery Directive 2006/42/EC published on the 9th June 2006

W Christie (Industrial) Ltd, Meadowbank Road, Rotherham S61 2NF, United Kingdom.

This machinery has been designed and manufactured in accordance with the following transposed harmonised European Standard:-

BS EN ISO 12100-2:2003 Safety of Machinery – Technical Principles

SIGNED: 

NAME: R. G. Askham

POSITION: Senior Applications Engineer

On behalf of W Christie (Industrial) Ltd



W. CHRISTIE (INDUSTRIAL) LTD
Christie House, Meadowbank Road,
Rotherham, South Yorkshire, S61 2NF
t: +44(0)1709 550088
e: info@wchristie.com
f: +44(0)1709 550030
w: www.wchristie.com



CHRISTIE
TOTAL TORQUE SOLUTIONS