

## 5000Nm HORIZONTAL RUNDOWN FIXTURE – TECHNICAL DATA

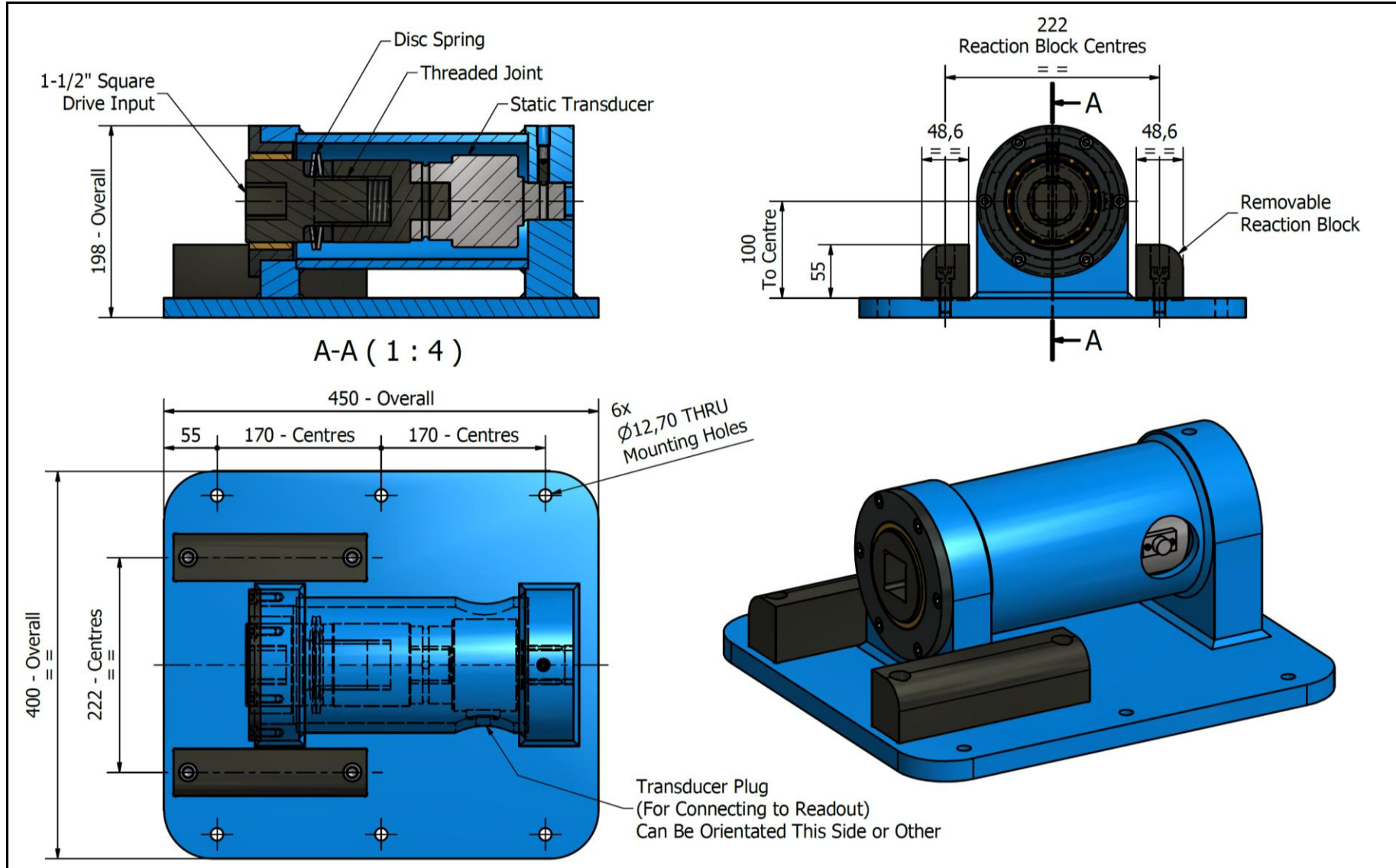

# 5000Nm HORIZONTAL RUNDOWN FIXTURE – TECHNICAL DATA

## DESCRIPTION

The Christie Horizontal Rundown Fixture is designed to simulate the working conditions of a screwed or bolted joint.

The Static Transducer is supplied with a calibration certificate. (Traceable to national standards)

The fixture is supplied with a static transducer and used in conjunction with a readout, the Rundown Assembly is used for non-impacting power tool testing and calibration.

For intermittent or short term use, the Horizontal Rundown Assembly can be supplied on a hire basis.

## SPECIFICATION

Input Square Drive (Female):	1-1/2" (38.1mm)
Tighten (Calibration) Direction:	Clockwise
Static Transducer Torque Accuracy:	+/- 0.5%
Transducer Minimum Calibrated Torque:	500 Nm (368.7 Lbf.ft)
Transducer Maximum Torque:	5,000 Nm (3,687.2 Lbf.ft)
Total Weight:	~67 Kg (147.71 lbs)
Reaction Layout:	As Shown
Base Mounting Configuration:	6 Holes Ø12.7mm
Grease (For Internal Thread):	Molybdenum Disulphide (Moly Benton Grease)

## ACCESSORIES AVAILABLE

The following accessories are available upon request and can be custom made to suit requirements. Please contact W. Christie (Industrial) Limited for more information:-

- Input Square Drive Reducing Sleeves
- Calibration Table – To suit your requirements
- Wrench Test Reaction

## RELATED TECHNICAL DATA SHEETS

The following technical data sheets may be of interest. Please contact W. Christie (Industrial) Limited for more information:-

- C-RAD Pneumatic Torque Wrench
- PM Pneumatic Torque Wrench
- BC-RAD Battery Torque Wrench

[No statement or data within this literature is warranted or guaranteed to be accurate.](#)



W. CHRISTIE (INDUSTRIAL) LTD  
CHRISTIE HOUSE  
MEADOWBANK ROAD  
ROTHERHAM  
SOUTH YORKSHIRE  
S61 2NF UK  
T: +44(0)1709 550088 F: +44(0)1709 550030  
E: [INFO@WCHRISTIE.COM](mailto:INFO@WCHRISTIE.COM) W: [WWW.WCHRISTIE.COM](http://WWW.WCHRISTIE.COM)