

CCR

CHRISTIE
TOTAL TORQUE SOLUTIONS



Heavy Duty Hydraulic Torque Tool

The open hexagon design of the CCR range of torque tools gives direct fitting onto the nut or bolt head. This tooling with robust steel construction is especially suited to applications with limited overhead access or with fasteners with excessive thread protrusion.



CCR HYDRAULIC

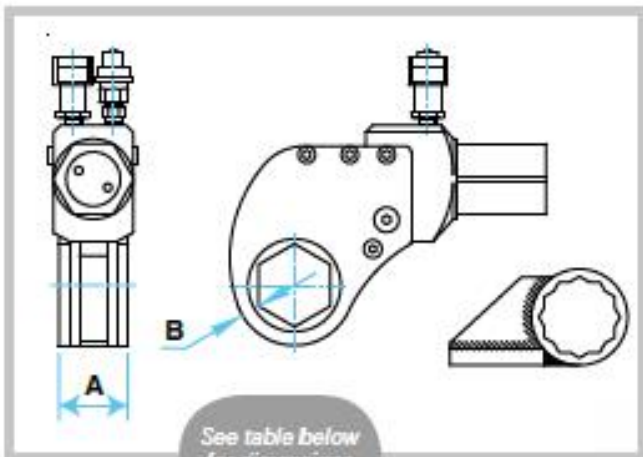

See table below for dimensions and details

- 12 position reaction
- Reversible operation
- Rapid double action operation
- Accurate to within +/-3%
- Corrosion resistant
- Conforms to European Standards for subsea and underground work
- Robust 100% steel construction

HIRE, SALES & ADVICE
01709 550088

The CCR tool is available with optional swivel couplings and special reactions

Model	Dimensions (mm)		Maximum A/F		Maximum Torque Nm
	A	B	Inch	mm	
CCR 1	38	11	1 ³ / ₁₆ "	41	1,360
CCR 1.5	41	12	2 ¹ / ₁₆ "	55	2,040
CCR 3	52	17	2 ¹ / ₈ "	65	4,488
CCR 5	58	16	3"	75	7,888
CCR 7	64	18	3 ¹ / ₈ "	80	10,060
CCR 11	82	20	4 ¹ / ₈ "	120	14,960
CCR 15	96	22	4 ¹ / ₈ "	120	20,400
CCR 20	100	25	5"	130	28,560
CCR 30	120	30	6 ¹ / ₈ "	155	43,520
CCR 50	147	38	8"	205	68,000
CCR 60	160	43	9"	230	81,350
CCR 80	180	51	10"	250	108,000

