

IBT

Hydraulic Torque Tool

IBT HYDRAULIC With a mono body design and alloy construction, the lightweight IBT torque tool range is perfect for those bolting jobs requiring the use of impact sockets and ancillaries.



- Accuracy within +/-3%
- 360° Swivel Coupler for easy hose alignment
- Single release button mechanism gives quick and easy change of reaction angle
- Push button release on square drive allows rapid change over from bolt tightening to un-tightening
- Square drive is interchangeable with direct fit outputs



HIRE, SALES & ADVICE
01709 550088

Smart Socket

Transducerized hexagonal socket for torque verification on non-impacting square drive torque tools



Refer to page 26 of our Hand Held Torque Tools brochure or visit our website for further details.

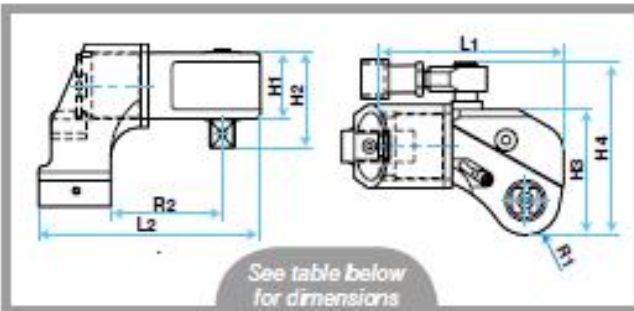

See table below for dimensions and details

Backing Tool (See page 22)



Model	Dimensions (mm)								Tool Weight Kg	Torque Range (Nm)		Square Drive
	L1	L2	H1	H2	H3	H4	R1	R2		Min	Max	
07 IBT	111	139	42	66	76.5	108.5	20.5	68	1.8	112	1,070	3/4"
1 IBT	140	169	50	72	95	131	26	85	2.5	183	1,755	3/4"
3 IBT	175	226	68	96	127	177	34	114	5	451	4,310	1"
5 IBT	207	267	80	123	149	198	39	141	8	752	7,190	1 1/2"
8 IBT	227	294	90	132	167	217	47	154	11	1,078	10,295	1 1/2"
10 IBT	246	318	100	141	181	230	51	154	15	1,551	14,820	1 1/2"
20 IBT	318	385	130	188	220	269	59	185	26.5	2,666	25,465	2 1/2"
25 IBT	333	402	137	200	248	297	66	199	35	3,472	33,160	2 1/2"
35 IBT	372.5	465.5	153	216	282	332	77	241	50	4,866	46,475	2 1/2"
50 IBT	400	516	160	223	291	341	81	259	87	7,200	68,760	2 1/2"