



CHRISTIE

Bespoke Engineered Solutions
A Division of W. Christie (Industrial) Ltd

Inspection Camera System



The W. Christie inspection camera system is the perfect tool for the visual inspection of 'out of reach' areas or difficult access situations.

This inspection camera system is both completely portable and easy to use. It also saves time by reducing the need to set-up access and safety equipment for visual inspection. This means visual inspections can be carried out more regularly, making it the perfect preventative maintenance tool.

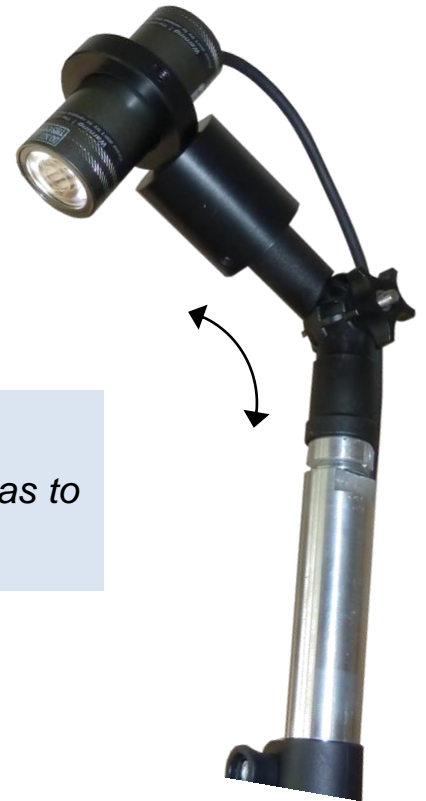

Routine Inspection of Rail Rolling Stock

Currently in use for the visual inspection of train roofing areas to check for general damage and integrity of roofing rivets.

- Easy to use, complete integral system – 'switch on and go'
- 1 person operation
- Save time and money due to minimal set-up required
- Costly repairs can be minimised when used as a preventative maintenance tool
- Light, yet robust
- Adjustable in both length and angle to allow positioning exactly where needed
- Provides clear images on the colour TFT screen, even in the dark
- Safe 12V power usage



5.6" Colour TFT monitor & control panel

Supplied complete with neck strap

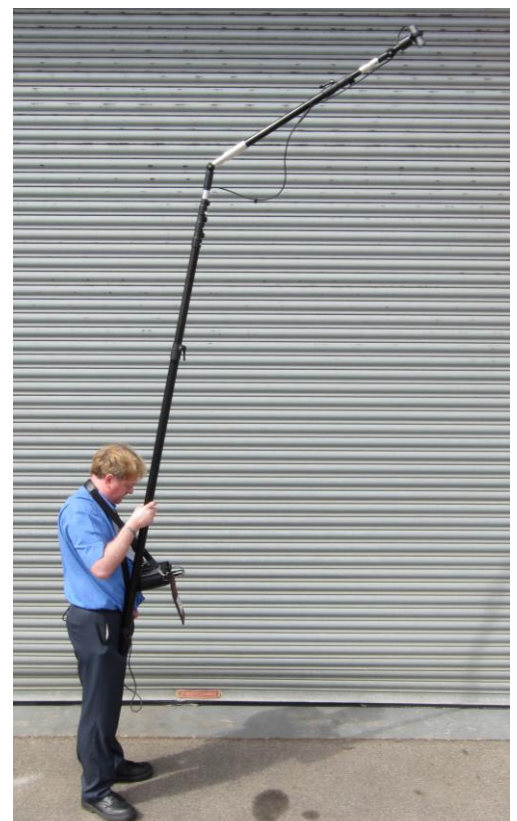

Inspection Camera System



CHRISTIE
Bespoke Engineered Solutions
A Division of W. Christie (Industrial) Ltd

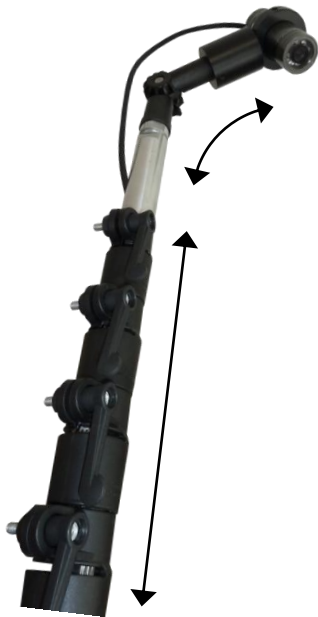

Technical Specifications

Telescopic Pole

- Main telescopic pole 1.7m in retracted position, 3m extended
- Adjustable angle extension arm 0.8m in retracted position, 1.5m extended
- Waist worn pole butt for stability when handling
- Quick release Duralok clamps
- Internal runs for camera cable
- 4 pin waterproof 'Din' connector for monitor
- Glass fibre material for strength and rigidity

Hi Resolution Colour Camera with White LED Lighting

- Sony CCD image chip
- High colour reproduction
- 12 volt power consumption
- Fitted to angle adapter for angle adjustment

Portable 5.6" Monitor

- LED back light
- Operates on high capacity Lithium batteries lasting up to 8 hours
- Zoom function for image enhancement
- Supplied with protective case and carry strap

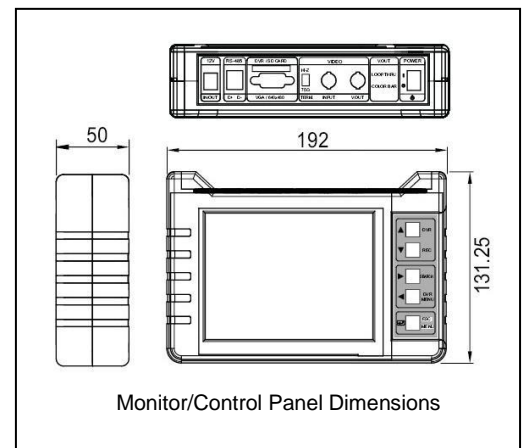

**Other pole and system configurations are available.
Call us to discuss your requirements further.**

No statement or data within this literature is warranted or guaranteed to be accurate.

W. CHRISTIE (INDUSTRIAL) LTD

CHRISTIE HOUSE, MEADOWBANK ROAD,
ROTHERHAM, SOUTH YORKSHIRE, S61 2NF UK
T: +44(0)1709 550088 F: +44(0)1709 550030
E: INFO@WCHRISTIE.COM

REGISTERED OFFICE: UNIT F7, FESTIVAL BUSINESS CENTRE,
150 BRAND STREET, GLASGOW, G51 1DH, SCOTLAND
T: +44(0)141 427 9801 F: +44(0)141 427 9802
E: WCHRISTIEGLW@BTCONNECT.COM
REGISTRATION NO: SC 035247

www.wchristie.com