

4AR 3/4" RATCHET INDUSTRIAL TORQUE WRENCH (NEW) - TECHNICAL DATA

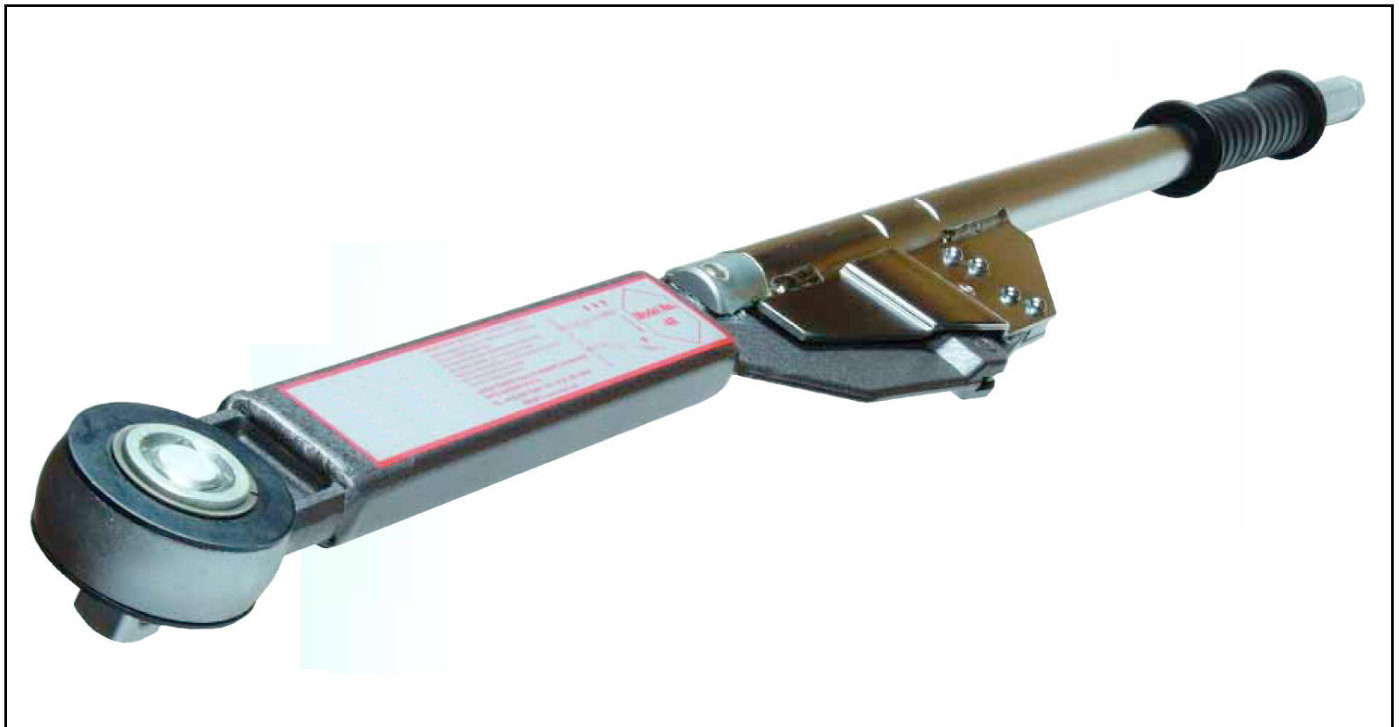
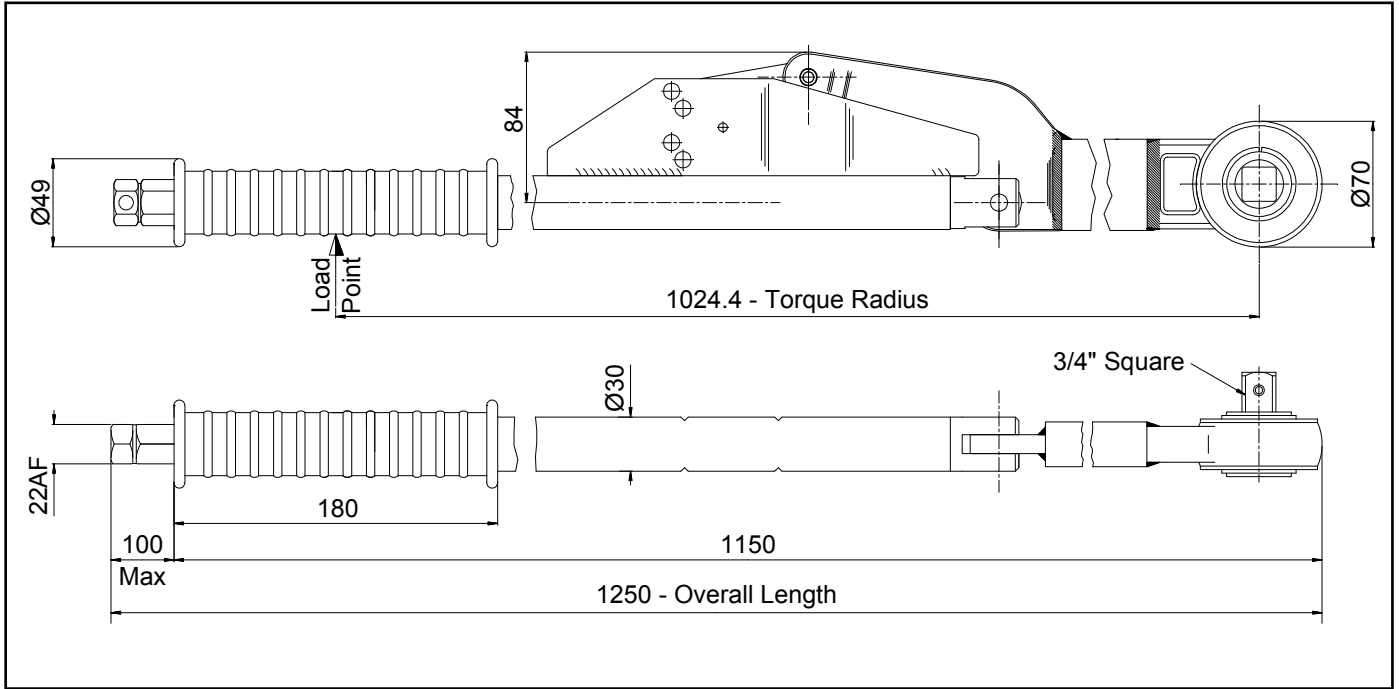

4AR 3/4" RATCHET INDUSTRIAL TORQUE WRENCH (NEW) - TECHNICAL DATA

DESCRIPTION

The 4AR 3/4" Ratchet Industrial Torque Wrench has a 'Break Back' action providing an unmistakable signal that can be seen and felt when the set torque is reached.

The 4AR Wrench is supplied with a calibration certificate.

The robust construction gives accurate results +/-4% even in arduous working conditions.

The break angle improves accuracy by reducing the possibility of over torquing.

The 4AR wrench is fully adjustable between the minimum and maximum torques specified, although it is available as a production (P) type with no setting scale. These are set using Christies professional torque tool tester. (Specify torque required at time of order)

SPECIFICATION

| | |
|------------------------|---|
| Part Number: | 12007 |
| Square Drive: | 3/4" (19.05mm) |
| Torque Radius: | 1024.4mm (40.33") |
| Torque Accuracy: | +/- 4% |
| Minimum Output Torque: | 200 Nm (150 lbf.ft) |
| Maximum Output Torque: | 800 Nm (600 lbf.ft) |
| Scale: | Nm & lbf.ft |
| Weight: | 6.4 Kg (14.11 lbs) |
| Ratchet Teeth: | 36 |
| Ratchet Type: | Push Through |
| Packaging: | High Quality Plastic Case (with space for sockets etc...) |

ACCESSORIES AVAILABLE

The following accessories are available upon request and can be custom made to suit requirements. Please contact W. Christie (Industrial) Limited for more information:-

- Impact Quality Sockets
- Torque Checking Equipment
- The wrench can be modified to accept custom spigot attachments.

No statement or data within this literature is warranted or guaranteed to be accurate.



W. CHRISTIE (INDUSTRIAL) LTD
CHRISTIE HOUSE
MEADOWBANK ROAD
ROTHERHAM
SOUTH YORKSHIRE
S61 2NF UK
T: +44(0)1709 550088 F: +44(0)1709 550030
E: INFO@WCHRISTIE.COM W: WWW.WCHRISTIE.COM