

## MANUAL TORQUE MULTIPLIER HT5-25:1 – TECHNICAL DATA

### PART 16090

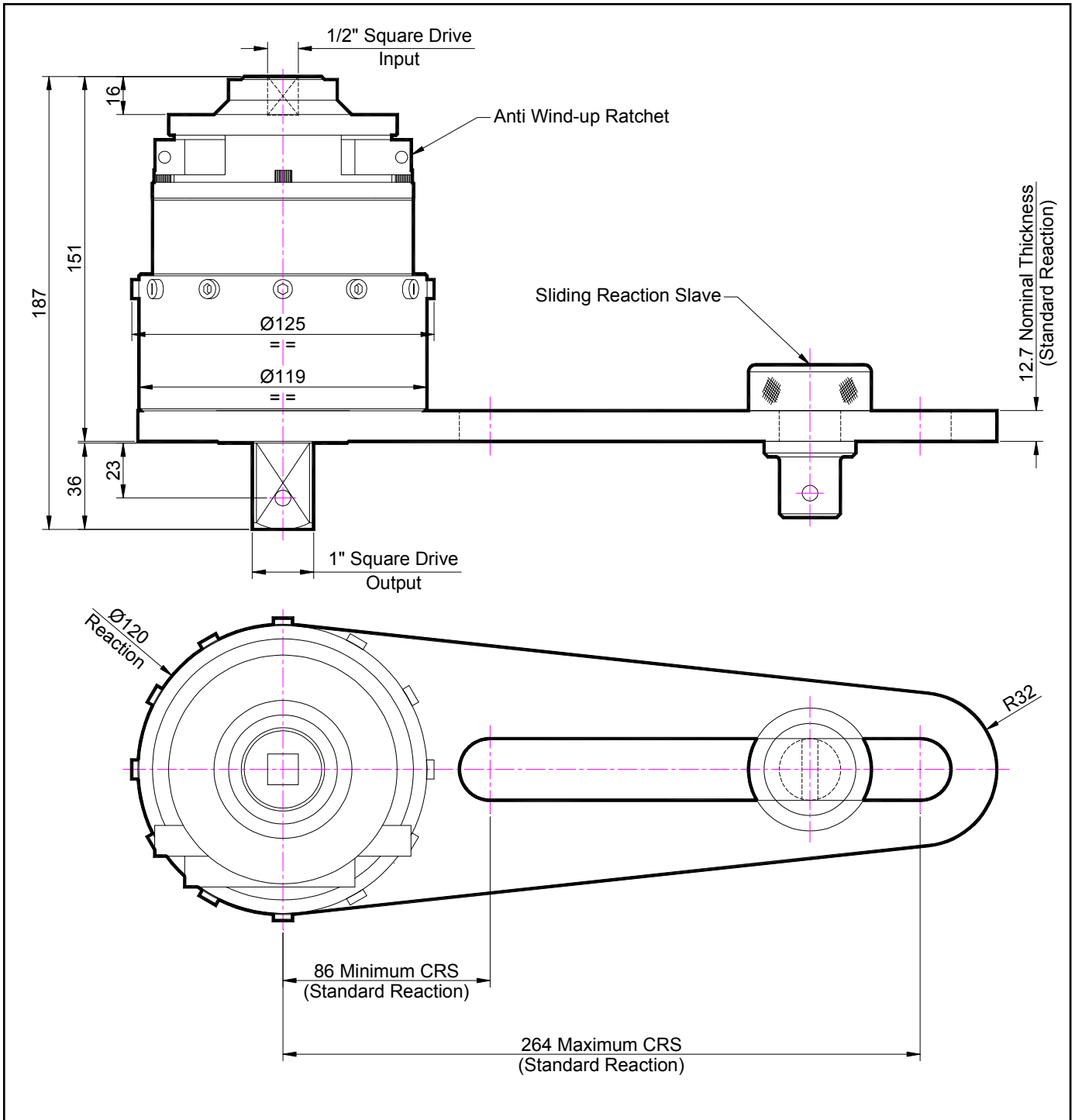

# MANUAL TORQUE MULTIPLIER HT5-25:1 – TECHNICAL DATA

## PART 16090

### DESCRIPTION

The Christie Manual Torque Multiplier employs multiple stages of epicyclic gearing to give a accurate torque output and ratio.

Ratio quoted is the torque multiplication ratio, not the velocity ratio as given for some competitor's products. For example, the velocity ratio may be 29.752:1 to give a torque multiplication of 25:1 +/-4%.

The reaction force works in the opposite direction to the applied torque. The point of reaction should be kept as far away as practicable from the centres of the square drive to minimise this force.

Where the standard reaction plate is not suitable, it may be possible to adapt it. Please contact W. Christie (Industrial) Limited for assistance.

The multiplier can be thought of as a spring which must be fully wound before any tightening / untightening work can be applied to the bolt. The anti wind-up ratchet ensures that the 'spring' stays wound and that any further torque input to the multiplier is applied directly to the bolt.

The unit must always be used with the following:-

- Impact Quality Sockets
- Reaction Arm
- Manual Torque Wrench

### SPECIFICATION

Part Number:	16090
Input Square:	1/2" Female (12.7mm)
Output Square:	1" Male (25.4mm)
Direction:	Forward / Reverse
Torque Accuracy:	+/- 4%
Torque Ratio:	25:1
Velocity Ratio:	29.752:1
Minimum Output Torque:	340 Nm (250 lbf.ft)
Maximum Output Torque:	3,400 Nm (2,500 lbf.ft)
Maximum Input Speed:	105 rpm
Tool Weight:	7.5 Kg (16.54 lbs)
Reaction Plate Weight:	2.5 Kg (5.52 lbs)

### ACCESSORIES AVAILABLE

The following accessories are available upon request and can be custom made to suit requirements. Please contact W. Christie (Industrial) Limited for more information:-

- Electronic Torque Transducers (For Precise Torque Monitoring)
- Manual Torque Wrench
- Special Reactions
- Impact Quality Sockets
- Torque Checking System (Rundown Fixture)

No statement or data within this literature is warranted or guaranteed to be accurate.



W. CHRISTIE (INDUSTRIAL) LTD  
CHRISTIE HOUSE  
MEADOWBANK ROAD  
ROTHERHAM  
SOUTH YORKSHIRE  
S61 2NF UK  
T: +44(0)1709 550088 F: +44(0)1709 550030  
E: [INFO@WCHRISTIE.COM](mailto:INFO@WCHRISTIE.COM) W: [WWW.WCHRISTIE.COM](http://WWW.WCHRISTIE.COM)